

Art. Nr.	Benaming	M.	Hoeveelheid
010.1558	STAFFA FISSAGGIO CILINDRO SPOR	NR	2,000
010.1835	SET ATTACCHI 117.4.12.P AX-CNC	NR	1,000
010.7221	DADO M16 BASSO	NR	4,000
010.7229	DADO AUTOBLOCCANTE M8	NR	2,000
010.7603	RONDELLA DIAM. 6	NR	2,000
010.7830	VITE BUTON 5 X 10	NR	12,000
010.7868	VITE TCEI 6 X 12	NR	2,000
013.0136	PIEDISTALLO	NR	1,000
016.0754	QUADRO ELETTRICO TI 370 CNC	NR	1,000
016.1481	STAFFA PROTEZIONE CILINDRO SPO	NR	1,000
016.1749	PROTEZIONE FINECORSA CARTER AL	NR	1,000
016.1773	PROTEZIONE CILINDRO BLOCCAGGIO	NR	1,000
022.0210	RACCORDO RAPIDO SEM PG 11	NR	2,000
022.0211	RACCORDO RAPIDO SEM PG 13,5	NR	1,000
022.0212	RACCORDO RAPIDO SEM PG 16	NR	2,000
022.0231	PRESSACAVO IN OTTONE 3/8 BM 24	NR	1,000
022.0234	PRESSACORDONE 3246 NERO PG 13,	NR	1,000
022.0241	DADO IN OTTONE BM 2461 3/8	NR	1,000
022.0244	CONTRODADO 3217B GRIGIO PG 13	NR	2,000
022.0245	CONTRODADO 3213B GRIGIO PG 11	NR	2,000
022.0249	DADO POLIAM.HUMMEL 1.262.1600.	NR	2,000
022.0324	PASSACAVI 24 INC.MM.2.5	NR	1,000
022.0507	FINECORSA D4C-1G02 1M	NR	1,000
034.0743	QUADRO PNEUMATICO SH 270 CNCFE	NR	1,000
034.0861	INSERTO NYLON X CILINDRO TI 37	NR	2,000
034.0901	TAPPO LIVELLO OLIO 1/2 "GAS.	NR	1,000
034.0905	TAPPO OLIO TAO/3 1/2" NERO	NR	1,000
034.1112	VOLANTINO DIAM.40 M8	NR	2,000
034.1451	CATENA PORTACAVI E17.04.63.0	MT	1,000
043.0051	CILINDRO	NR	2,000
043.0143	PRESSOSTATO PNEUM.PS1P1091	NR	1,000
043.0153	BLOCCO DI VALVOLE DA 4 TI 370	NR	1,000
043.0198	ATTACCO A GOMITO GIREV.4X1/4 C	NR	3,000
043.0202	ATTACCO A ESAGONO 8X1/8 - CL 6	NR	12,000
043.0204	ATTACCO A GOMITO 8X1/4 - CL 65	NR	2,000
043.0205	ATTACCO A ESAGONO 8X1/4 - CL 6	NR	1,000
043.0206	ATTACCO A ESAGONO 4X1/8 - CL 6	NR	3,000
043.0219	RACCORDO A" T" MFF 1/4" CL-2070	NR	1,000
043.0235	BIFORCAZ. A Y TUBO 4MM. 242753	NR	1,000
043.0261	TAPPO TTE8 1/8 - CL 2611	NR	1,000
043.0281	MANICOTTO 1/8 M 8/8 - CL 2543	NR	4,000
043.0290	INNESTO RAPIDO 1/4 GHIOTTO 13/	NR	2,000
043.0301	TUBO RILSAN 8X6 NERO COD.172	MT	6,000
043.0302	TUBO RILSAN 4X2.7 BIANCO C.172	MT	5,000
043.0472	SILENZIATORE 1/4- PLASTICA	NR	2,000
043.0552	MANOMETRO DIAM. 40	NR	1,000
043.0564	FR 1/4 20-08	NR	1,000
043.0601	VALVOLA VMS 114-1/4 08	NR	1,000

Vaste-tafel groep

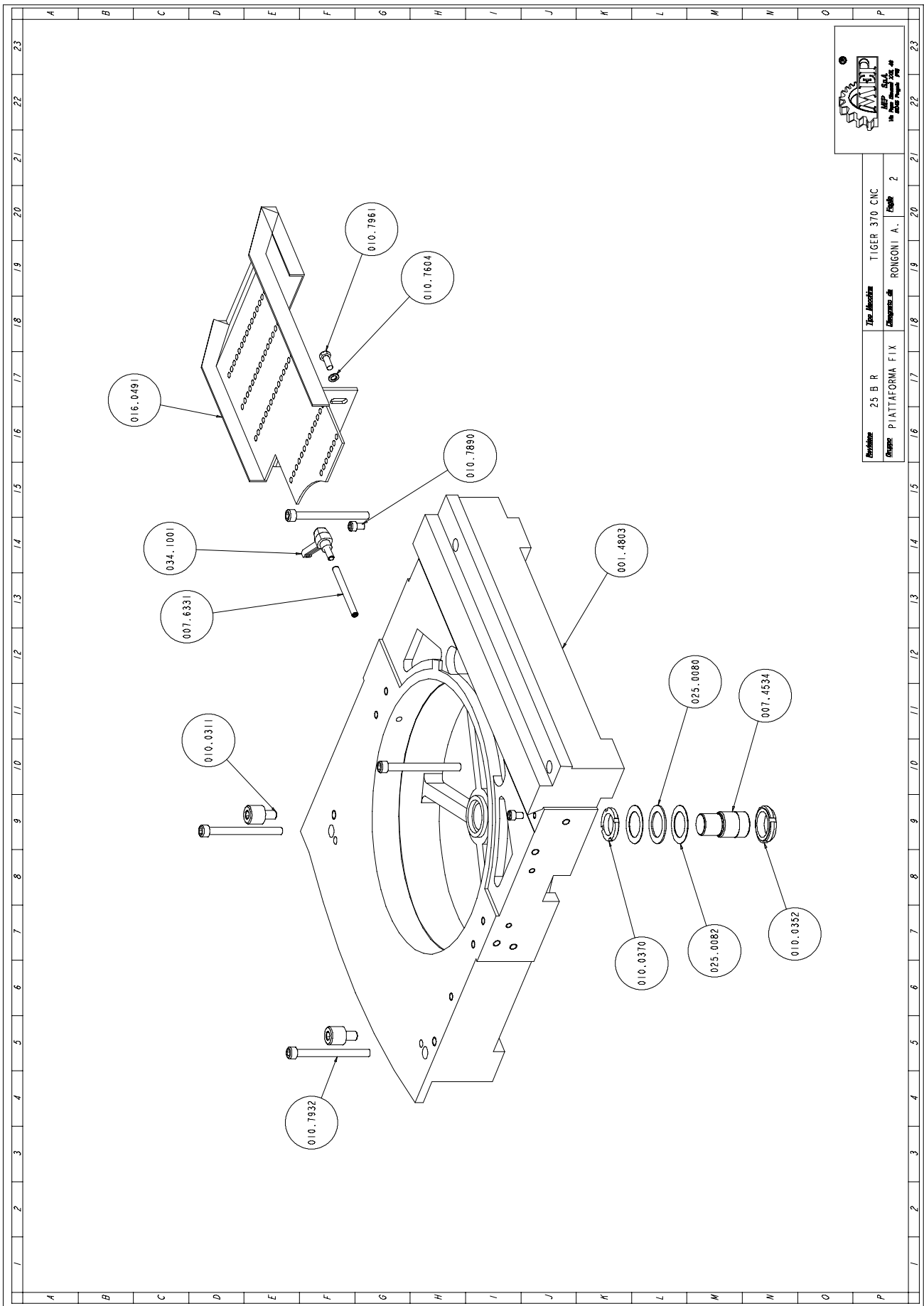

Art. Nr.	Benaming	M.	Hoeveelheid
001.4803	PIATTAFORMA	NR	1,000
007.4534	PERNO DI CENTRO	NR	1,000
007.6331	PERNO BLOCCAGGIO PIANO GIREVOLE	NR	1,000
010.0311	VITE TCEI M12X16 BATT.PIANO GIREVO.	NR	2,000
010.0352	GHIERA AUTOBLOCCANTE 35X1,5	NR	1,000
010.0370	GHIERA 5S 30X1,5	NR	1,000
010.7604	RONDELLA DIAM. 8	NR	2,000
010.7890	VITE TCEI 8 X 12	NR	2,000
010.7932	VITE TCEI 10 X 110	NR	4,000
010.7961	VITE TE 8 X 20	NR	2,000
016.0491	GUIDA SCARICA PEZZI TI 370 CNC	NR	1,000
025.0080	GABBIA ASSIALE A RULLINI AXK 3552	NR	1,000
025.0082	RALLA AS 3552	NR	2,000
034.1001	LEVA A SCATTO 8 MA PK55	NR	1,000

Draaitafel

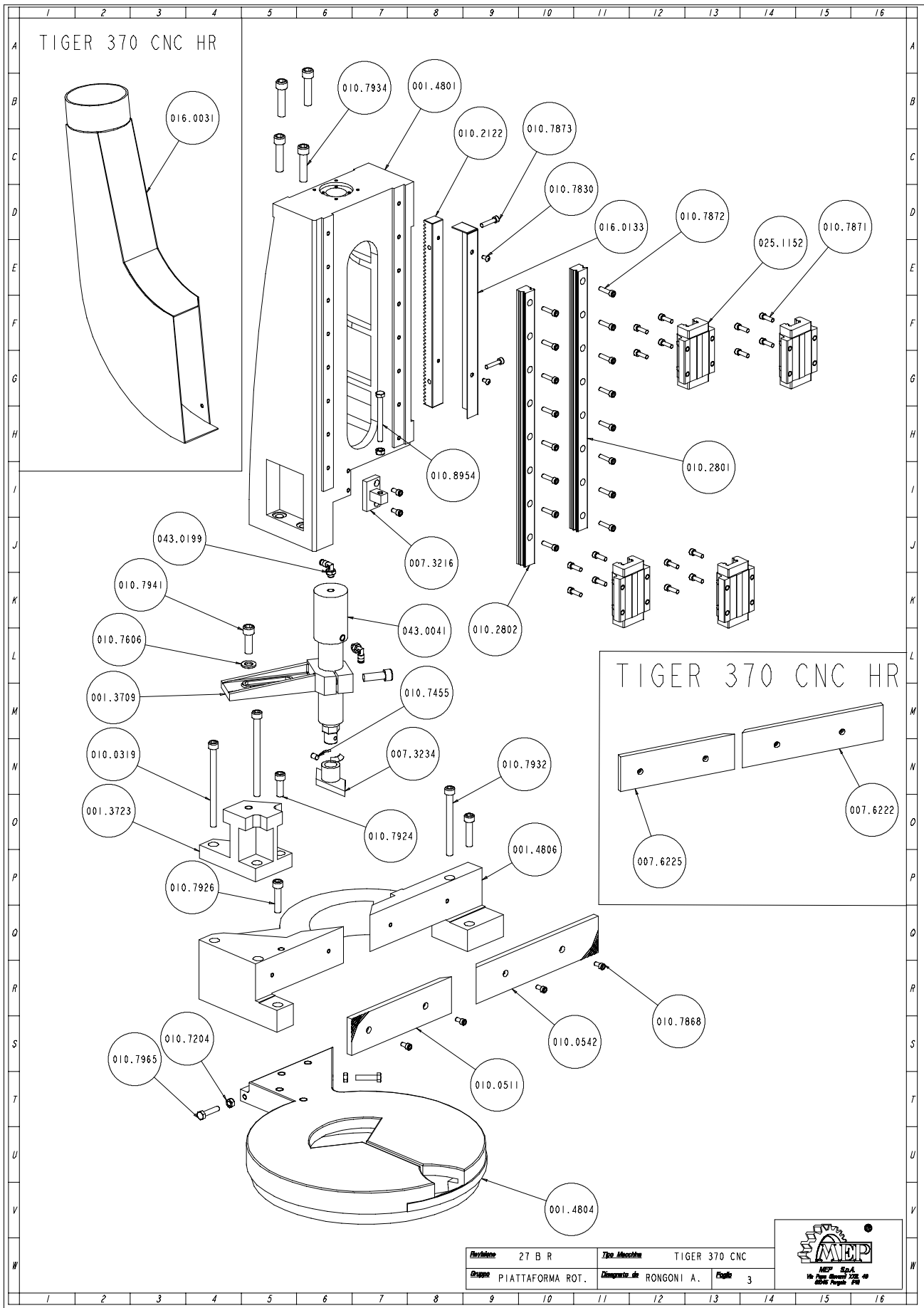

Art. Nr.	Benaming	M.	Hoeveelheid
001.3709	STAFFA BLOCCAGGIO CILINDRO SUP	NR	1,000
001.3723	SUPPORTO CILINDRO SUPPLEMENTAR	NR	1,000
001.4801	COLONNA PORTANTE	NR	1,000
001.4804	PIATTAFORMA ROTANTE	NR	1,000
001.4806	SQUADRO MORSA	NR	1,000
007.3216	BATTUTA FINECORSO	NR	1,000
007.3234	BOCCOLA/GANASCIA X CILIN.SUPPL	NR	1,000
007.6222	GANASCIA MORSA DESTRA	NR	1,000
007.6225	GANASCIA MORSA SINISTRA TI 370	NR	1,000
010.0319	VITE 8.8 TCEI 10X140 TI	NR	2,000
010.1201	VITERIA E BULLONERIA	NR	1,000
010.2122	CREMAGLIERA TI 370 CNCFE	NR	1,000
010.2801	GUIDA PATTINO	NR	1,000
010.2802	GUIDA PATTINO	NR	1,000
010.7204	DADO M8	NR	3,000
010.7455	GRANO VCE P.CON. 8 X 10	NR	1,000
010.7606	RONDELLA DIAM. 12	NR	1,000
010.7830	VITE BUTON 5 X 10	NR	2,000
010.7868	VITE TCEI 6 X 12	NR	6,000
010.7871	VITE TCEI 6 X 20	NR	16,000
010.7872	VITE TCEI 6 X 25	NR	16,000
010.7873	VITE TCEI 6 X 30	NR	2,000
010.7924	VITE TCEI 10 X 30	NR	1,000
010.7926	VITE TCEI 10 X 45	NR	2,000
010.7932	VITE TCEI 10 X 110	NR	1,000
010.7934	VITE TCEI 12 X 50	NR	4,000
010.7941	VITE TCEI 12 X 35	NR	2,000
010.7965	VITE TE 8 X 35	NR	2,000
016.0031	CONVOGLIATORE TRUCIOLI TI 370	NR	1,000
016.0133	CARTER CREMAGLIERA SOLLEVAMENT	NR	1,000
025.1152	PATTINO LGW25HCZ3C	NR	4,000
043.0041	CILINDRO MORSE 50X10 0 40 L.15	NR	1,000
043.0199	ATTACCO A GOMITO GIREV.4X1/8 C	NR	2,000

Klemgroep

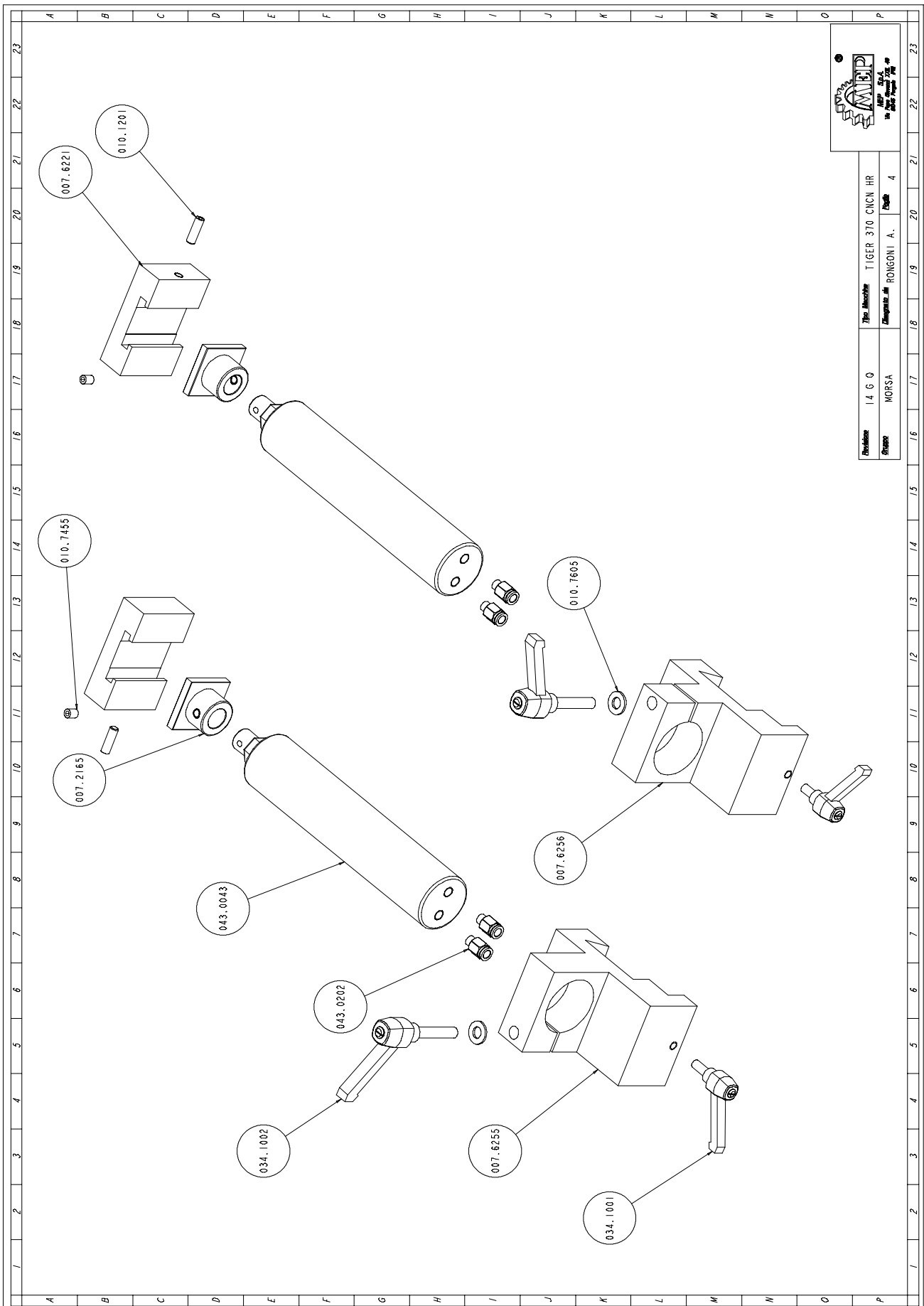

		Revizija	14 G O	Titel	TIGER 370 CNC HR
		Strana	MORSA	Projektant	ROINGONI A.
				Stranica	4

Art. Nr.	Benaming	M.	Hoeveelheid
007.2165	SUPPORTO GANASCIA MORSA	NR	2,000
007.6221	GANASCIA MORSA MOBILE	NR	2,000
007.6255	SUPPORTO CILINDRO MORSA DESTRA	NR	1,000
007.6256	SUPPORTO CILINDRO MORSA SINIST	NR	1,000
010.1201	VITERIA E BULLONERIA	NR	2,000
010.7455	GRANO VCE P.CON. 8 X 10	NR	2,000
010.7605	RONDELLA DIAM. 10	NR	2,000
034.1001	LEVA A SCATTO 8 MA PK55	NR	2,000
034.1002	LEVA A SCATTO 10 MA	NR	2,000
043.0043	CILINDRO MORSE 0 50 C8 D.E.	NR	2,000
043.0202	ATTACCO A ESAGONO 8X1/8 - CL 6	NR	4,000

Hoofd eenheid

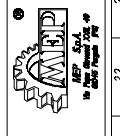
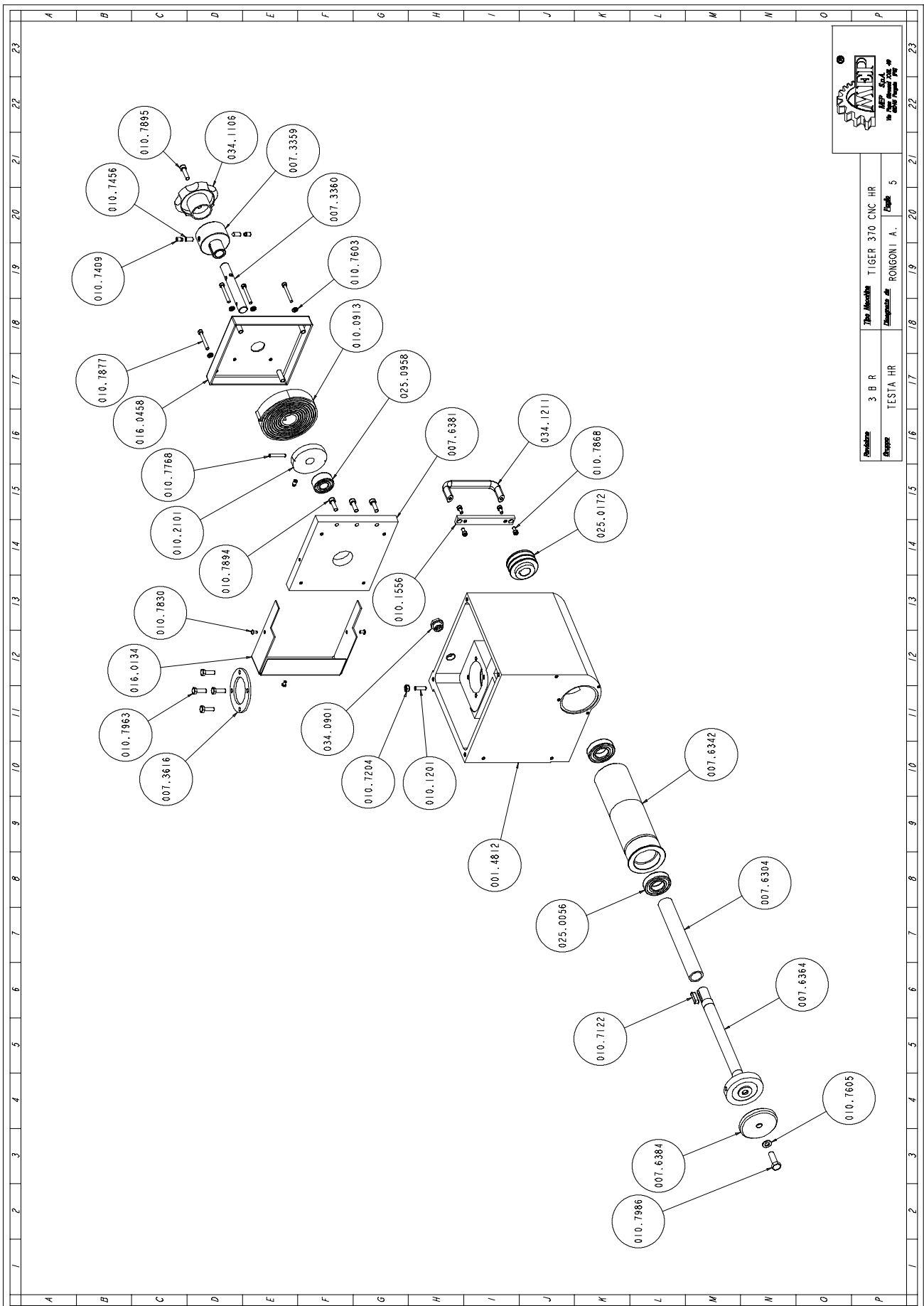

Residence	3 B R	The Machine	TIGER 370 CNC HR
Shop	TESTA HR	Manager	ROGONI A.
		Page	5

Art. Nr.	Benaming	M.	Kvantum
001.4812	.TESTA OPERATRICE TI 370 CNCHR	NR	1,000
007.3359	BOCCOLA RIPRESA CORSA	NR	1,000
007.3616	GHIERA FIX CUSCINETTO	NR	1,000
007.6304	DISTANZIALE CUSCINETTI ALBERO	NR	1,000
007.6342	TAMPONE TI 370 CNCHR	NR	1,000
007.6362	ALBERO MOVIMENTO TESTA TI 370	NR	1,000
007.6364	ALBERO PORTADISCO TI 370 CNCHR	NR	1,000
007.6381	FLANGIA PORTAMOLLA RICHIAMO TE	NR	1,000
007.6384	FLANGIA ESTERNA PORTADISCO TI	NR	1,000
010.0913	MOLLA SOLLEVAMENTO TESTA	NR	1,000
010.1201	VITERIA E BULLONERIA	NR	1,000
010.1556	STAFFA FISSAGGIO MANIGLIA TEST	NR	1,000
010.2101	RUOTA SOLLEVAMENTO TESTA	NR	1,000
010.7122	CHIAVETTA 8 X 8 X 32	NR	1,000
010.7204	DADO M8	NR	1,000
010.7409	GRANO VCE P.CIL. 8 X 10	NR	3,000
010.7456	GRANO VCE P.CON. 8 X 16	NR	2,000
010.7603	RONDELLA DIAM. 6	NR	4,000
010.7605	RONDELLA DIAM. 10	NR	1,000
010.7768	SPINA ELASTICA DIAM. 6 X 40	NR	1,000
010.7830	VITE BUTON 5 X 10	NR	3,000
010.7858	VITE TCEI 5 X 10	NR	6,000
010.7868	VITE TCEI 6 X 12	NR	4,000
010.7877	VITE TCEI 6 X 45	NR	4,000
010.7894	VITE TCEI 8 X 25	NR	3,000
010.7895	VITE TCEI 8 X 30	NR	1,000
010.7963	VITE TE 8 X 25	NR	4,000
010.7986	VITE TE 12 X 35	NR	1,000
016.0134	CARTER RUOTA SOLLEVAMENTO TEST	NR	1,000
016.0458	COPERCHIO MOLLA	NR	1,000
025.0056	CUSCINETTO 62.06 2Z C3	NR	2,000
025.0172	PULEGGIA 60X2 SPZ FORO 24	NR	1,000
025.0248	ANELLO DI TENUTA OR PARKER 2-3	NR	1,000
025.0958	CUSCINETTO 3204 A 2RS	NR	1,000
034.0901	TAPPO LIVELLO OLIO 1/2 "GAS.	NR	1,000
034.1106	VOLANTINO DIAM.100 A 6 LOBI	NR	1,000
034.1211	MANIGLIA GN-565-20-128.SW	NR	1,000

Zaagmotor

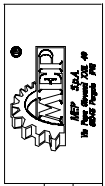
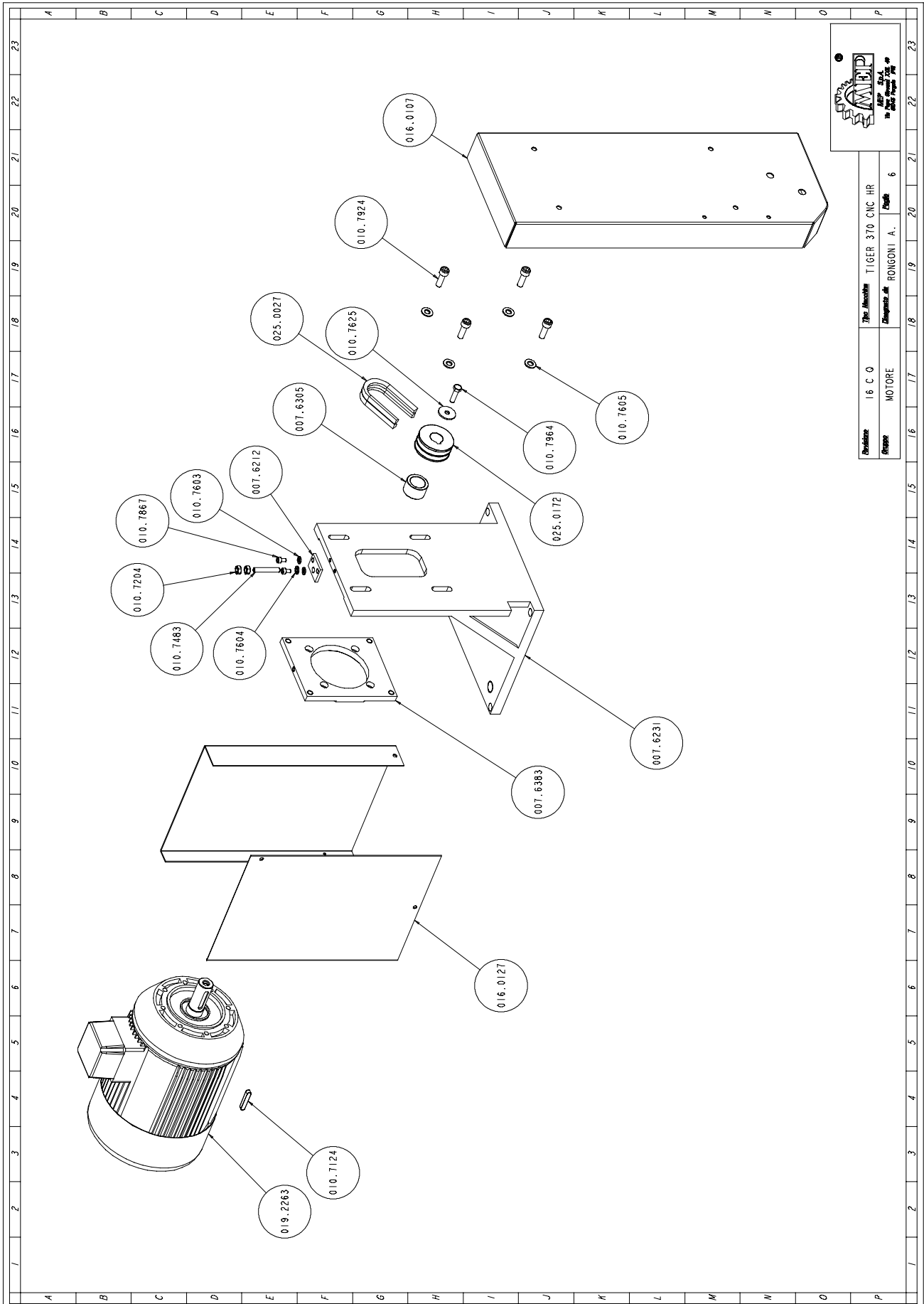

Revisie	16 C O	The Machine	TIGER 370 CNC HR
Stapel	MOTORE	Assemblage nr.	RONGONI A. Pagina 6

Art. NR.	Benaming	M.	Hoeveelheid
007.6212	PIASTRINO X REGOLAZIONE POSIZI	NR	1,000
007.6231	SQUADRO SUPPORTO MOTORE TI 370	NR	1,000
007.6305	DISTANZIALE PULEGGIA MOTORE TI	NR	1,000
007.6383	FLANGIA MOTORE REGOLABILE TI 3	NR	1,000
010.7124	CHIAVETTA 8 X 7 X 45	NR	1,000
010.7204	DADO M8	NR	2,000
010.7483	GRANO VCE PUNTA PIANA 8X50	NR	1,000
010.7603	RONDELLA DIAM. 6	NR	2,000
010.7604	RONDELLA DIAM. 8	NR	1,000
010.7605	RONDELLA DIAM. 10	NR	4,000
010.7625	RONDELLA DIAM. 8 X 32	NR	1,000
010.7867	VITE TCEI 6 X 10	NR	2,000
010.7924	VITE TCEI 10 X 30	NR	4,000
010.7964	VITE TE 8 X 30	NR	1,000
016.0107	CARTER CINGHIA DI TRASMISSIONE	NR	1,000
016.0127	CARTER MOTORE TI 370 CNCHR	NR	1,000
019.2263	KW 4,4/3,3 2/4P.B.14 GR112 V.	NR	1,000
025.0027	CINGHIA SPZ 1180	NR	2,000
025.0172	PULEGGIA 60X2 SPZ FORO 24	NR	1,000

Eenheid ter afdekking zaagblad

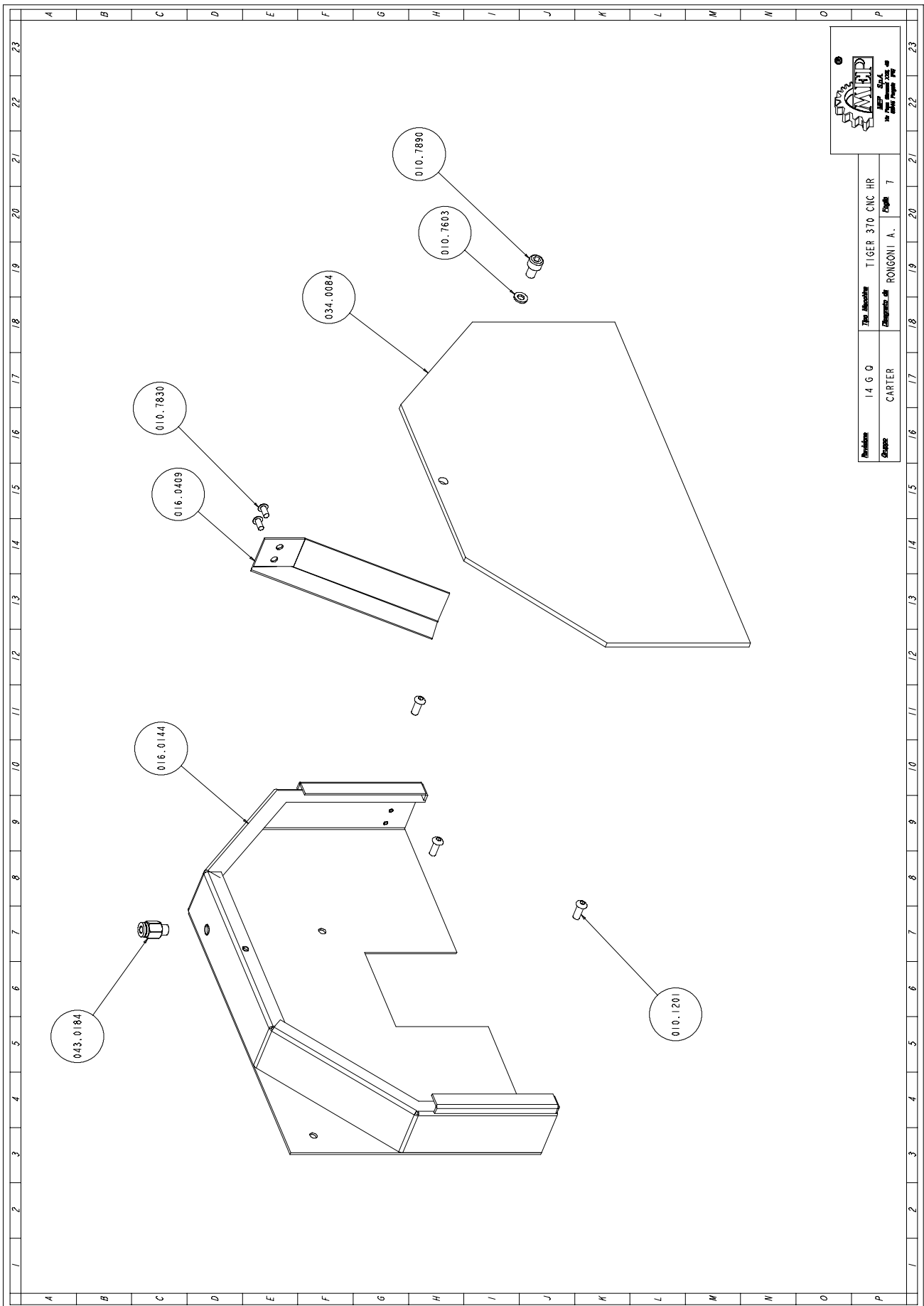

Art. NR.	Benaming	M.	Hoeveelheid
010.1201	VITERIA E BULLONERIA	NR	3,000
010.7603	RONDELLA DIAM. 6	NR	1,000
010.7830	VITE BUTON 5 X 10	NR	2,000
010.7890	VITE TCEI 8 X 12	NR	1,000
016.0144	CARTER FISCO TIGER 370 HR-MR	NR	1,000
016.0409	PARATRUCIOLI TI 370 HR-MR	NR	1,000
034.0084	PROTEZIONE LEXAN CARTER LAMA T	NR	1,000
043.0184	ATTACCO A ESAGONO 6X1/8 CL 651	NR	1,000

Groep electrocilinder

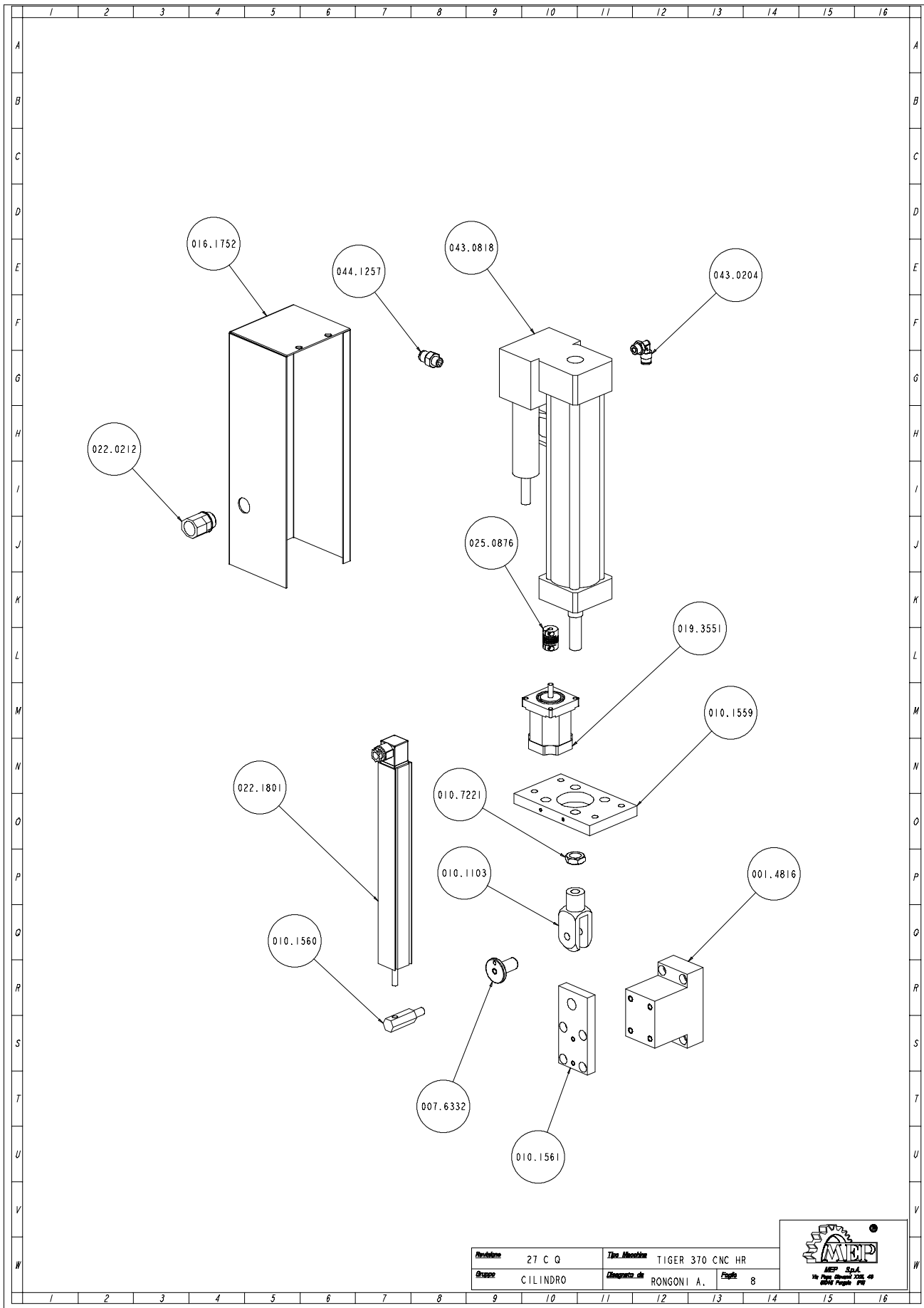

Art. Nr.	Benaming	M.	Hoeveelheid
001.4816	.SUPPORTO AGGANCIIO CILINDRO TI	NR	1,000
007.6332	PERNO FORCELLA TI 370 SX	NR	1,000
010.1103	FORCELLA 16 X 1,5	NR	1,000
010.1559	STAFFA FISSAGGIO CILINDRO TI 3	NR	1,000
010.1560	STAFFA TRASCINAMENTO POTENZIOM	NR	1,000
010.1561	STAFFA AGGANCIIO CILINRO TI 370	NR	1,000
010.7221	DADO M16 BASSO	NR	1,000
016.1752	PROTEZIONE CILINDRO	NR	1,000
019.3551	MOTORE MAE MOD.HY 200 2232 190	NR	1,000
022.0212	RACCORDO RAPIDO SEM PG 16	NR	1,000
022.0378	CONNETT.BOBINA VALV. RIGENERAT	NR	1,000
022.1801	POTENZIOMETRO LINEARE LWH225-0	NR	1,000
025.0876	GIUNTO WA 6-6 MM.28 X CILINDRO	NR	1,000
043.0204	ATTACCO A GOMITO 8X1/4 - CL 65	NR	1,000
043.0818	UNITA' IDROPNEUMATICA 63RBRSM	NR	1,000
044.1257	VALVOLA DI CARICO CILINDRO	NR	1,000

Groep toevoerwagen

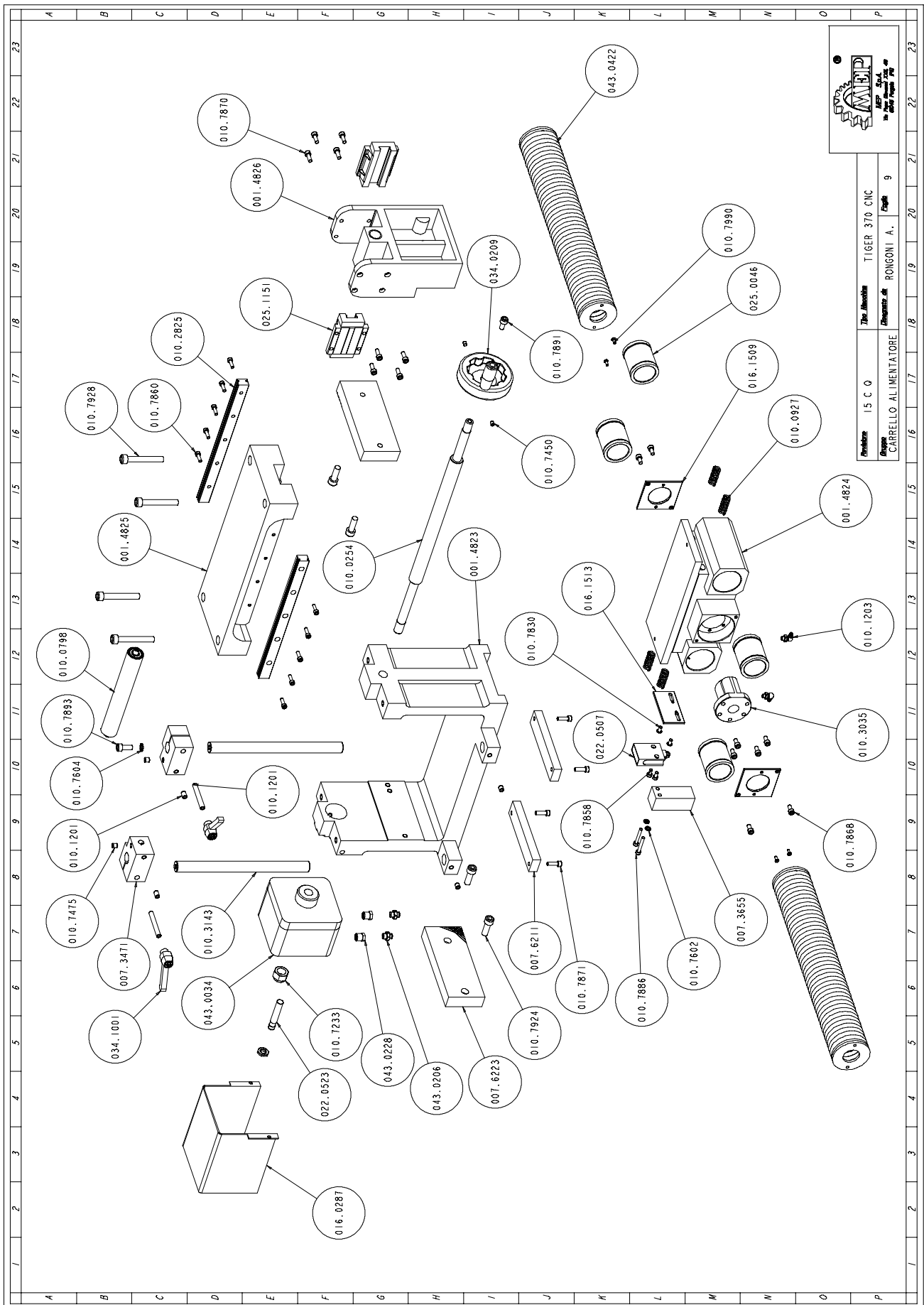

Art. Nr.	Benaming	M.	Hoeveelheid
001.4823	SLITTA BASCULANTE ALIMENTATORE	NR	1,000
001.4824	CARRELLO ALIMENTATORE	NR	1,000
001.4825	TRAVERSA SLITTA BASCULANTE ALI	NR	1,000
001.4826	STAFFA FISSAGGIO GANASCIA MOBI	NR	1,000
007.3471	TASSELLO FISSAGGIO RULLO PREMI	NR	2,000
007.3655	SUPPORTO CATENA PORTACAVI CN 9	NR	1,000
007.6211	PIASTRINO REGOLAZIONE SLITTA B	NR	2,000
007.6223	GANASCIA ALIMENTATORE	NR	2,000
010.0254	VITE MORSA ALIMENTATORE 535X24	NR	1,000
010.0798	RULLO PREMIBARRA ALIMENTATORE	NR	1,000
010.0927	MOLLA CARRELLO ALIMENTATORE	NR	4,000
010.1201	VITERIA E BULLONERIA	NR	4,000
010.1203	OLIATORE A 90° 6X1	NR	2,000
010.2825	GUIDA PATTINO HGR 20 R 0280 C	NR	2,000
010.3035	CHIOCCIOLA RNFTL2010A25S	NR	1,000
010.3143	SUPPORTO RULLO PREMIBARRA	NR	2,000
010.7233	DADO AUTOBLOCCANTE M16	NR	1,000
010.7450	GRANO VCE P.CIL. 6 X 6	NR	2,000
010.7475	GRANO VCE P.PIANA 8 X 8	NR	4,000
010.7602	RONDELLA DIAM. 5	NR	2,000
010.7604	RONDELLA DIAM. 8	NR	1,000
010.7830	VITE BUTON 5 X 10	NR	2,000
010.7858	VITE TCEI 5 X 10	NR	2,000
010.7860	VITE TCEI 5 X 15	NR	10,000
010.7868	VITE TCEI 6 X 12	NR	8,000
010.7870	VITE TCEI 6 X 16	NR	8,000
010.7871	VITE TCEI 6 X 20	NR	4,000
010.7886	VITE TCEI 5 X 35	NR	2,000
010.7891	VITE TCEI 8 X 16	NR	1,000
010.7893	VITE TCEI 8 X 20	NR	1,000
010.7924	VITE TCEI 10 X 30	NR	4,000
010.7928	VITE TCEI 10 X 70	NR	4,000
010.7990	VITE TSPEI 4 X 8	NR	4,000
016.0287	PROTEZIONE VOLAMPRESS	NR	1,000
016.1509	STAFFA FIX SOFFIETTO CIRCOLARE	NR	2,000
016.1513	STAFFA FIX MICROINTERRUTTORE	NR	1,000
022.0507	FINECORSO D4C-1G02 1M	NR	1,000
022.0523	SENSORE DI PROSSIMITA' PNP	NR	1,000
025.0046	MANICOTTO A SFERA 0658.040.00	NR	4,000
025.1151	PATTINO LGW20HAZ1C	NR	2,000
034.0209	VOLANTINO VDO.100 ALIMENTATORE	NR	1,000
034.1001	LEVA A SCATTO 8 MA PK55	NR	2,000
043.0034	CILINDRO VOLAMPRESS 100-8 ALIM	NR	1,000
043.0229	RIDUZIONE MF 1/4 - CL 2520	NR	2,000
043.0422	SOFFIETTO CIRCOLARE ALIMENTATO	NR	2,000

Rollenbandgroep toevoerinrichting

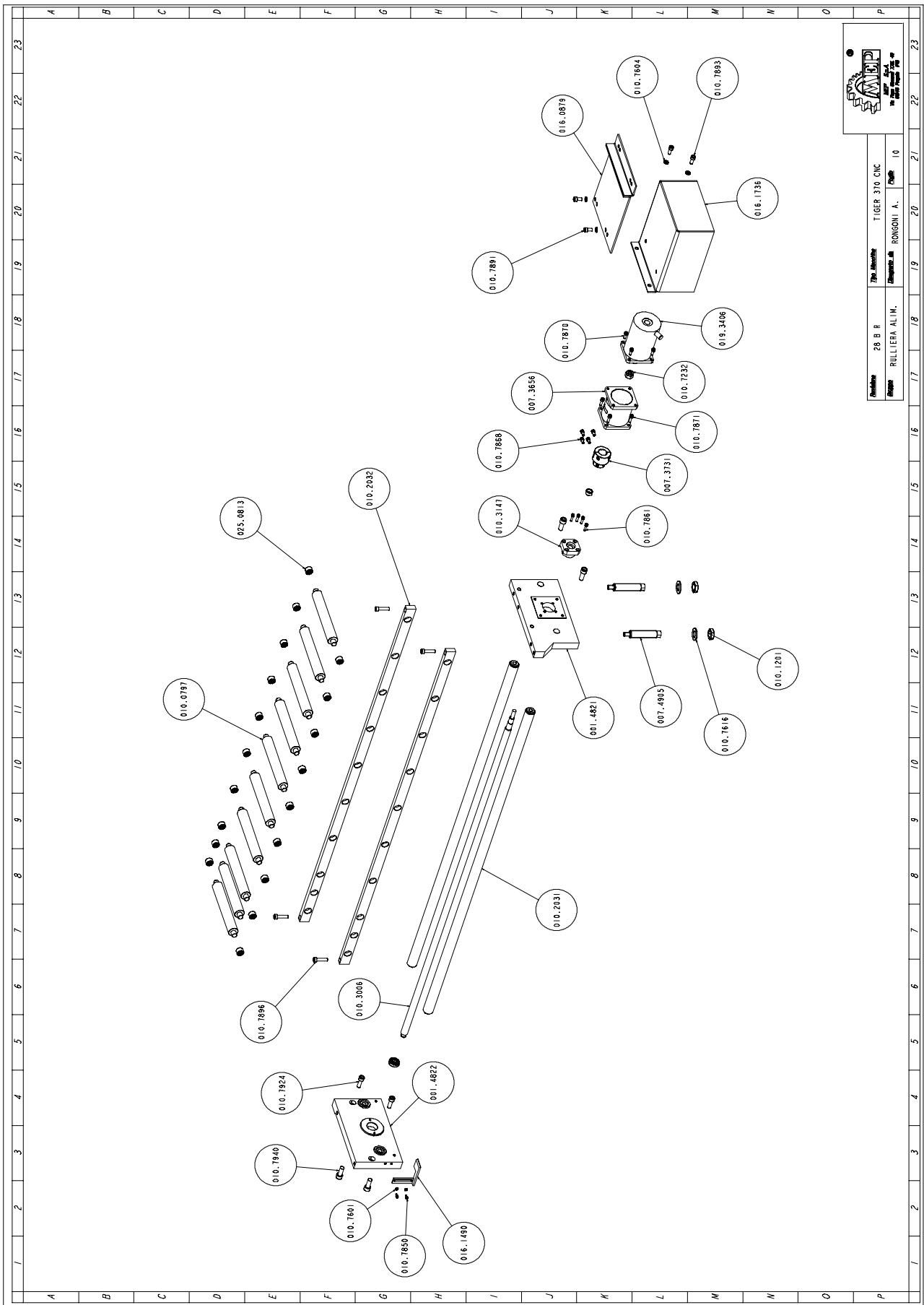

Art. Nr.	Benaming	M.	Hoeveelheid
001.4821	STAFFA POSTERIORE ALIMENTATORE	NR	1,000
001.4822	STAFFA ANTERIORE ALIMENTATORE	NR	1,000
007.3656	SUPPORTO MOTORE P/P ALIMENTATO	NR	1,000
007.3731	GIUNTO MOTORE ALIMENTATORE CN	NR	1,000
007.4905	SUPPORTO ALIMENTATORE SH 400	NR	2,000
010.0797	RULLO ALIMENTATORE	NR	10,000
010.1201	VITERIA E BULLONERIA	NR	2,000
010.2032	GUIDA RULLI ALIMENTATORE	NR	2,000
010.3006	VITE A RICIRCOLO DI SFERE 0 20	NR	1,000
010.3055	GUIDA CARRELLO 0 40 MM.1283	NR	2,000
010.3147	SUPPORTO VITE RULLATA	NR	1,000
010.7232	DADO AUTOBLOCCANTE M14	NR	1,000
010.7601	RONDELLA DIAM. 4	NR	2,000
010.7604	RONDELLA DIAM. 8	NR	4,000
010.7616	RONDELLA DIAM. 21	NR	2,000
010.7850	VITE TCEI 4 X 8	NR	2,000
010.7861	VITE TCEI 5 X 20	NR	4,000
010.7868	VITE TCEI 6 X 12	NR	8,000
010.7870	VITE TCEI 6 X 16	NR	4,000
010.7871	VITE TCEI 6 X 20	NR	4,000
010.7891	VITE TCEI 8 X 16	NR	2,000
010.7893	VITE TCEI 8 X 20	NR	2,000
010.7896	VITE TCEI 8 X 35	NR	4,000
010.7924	VITE TCEI 10 X 30	NR	2,000
010.7940	VITE TCEI 12 X 30	NR	4,000
016.0879	ADATTATORE DI CARICO PIANALE K	NR	1,000
016.1490	STAFFA COMANDO MICROINTERRUTT.	NR	1,000
016.1736	PROTEZIONE MOTORE ALIMENTATORE	NR	1,000
019.3406	MOTORE P/P SM88.2.18M8 ALIMENT	NR	1,000
025.0813	BOCCOLA A RULLINI INA HK 1512	NR	20,000

Bedieningspaneel groep

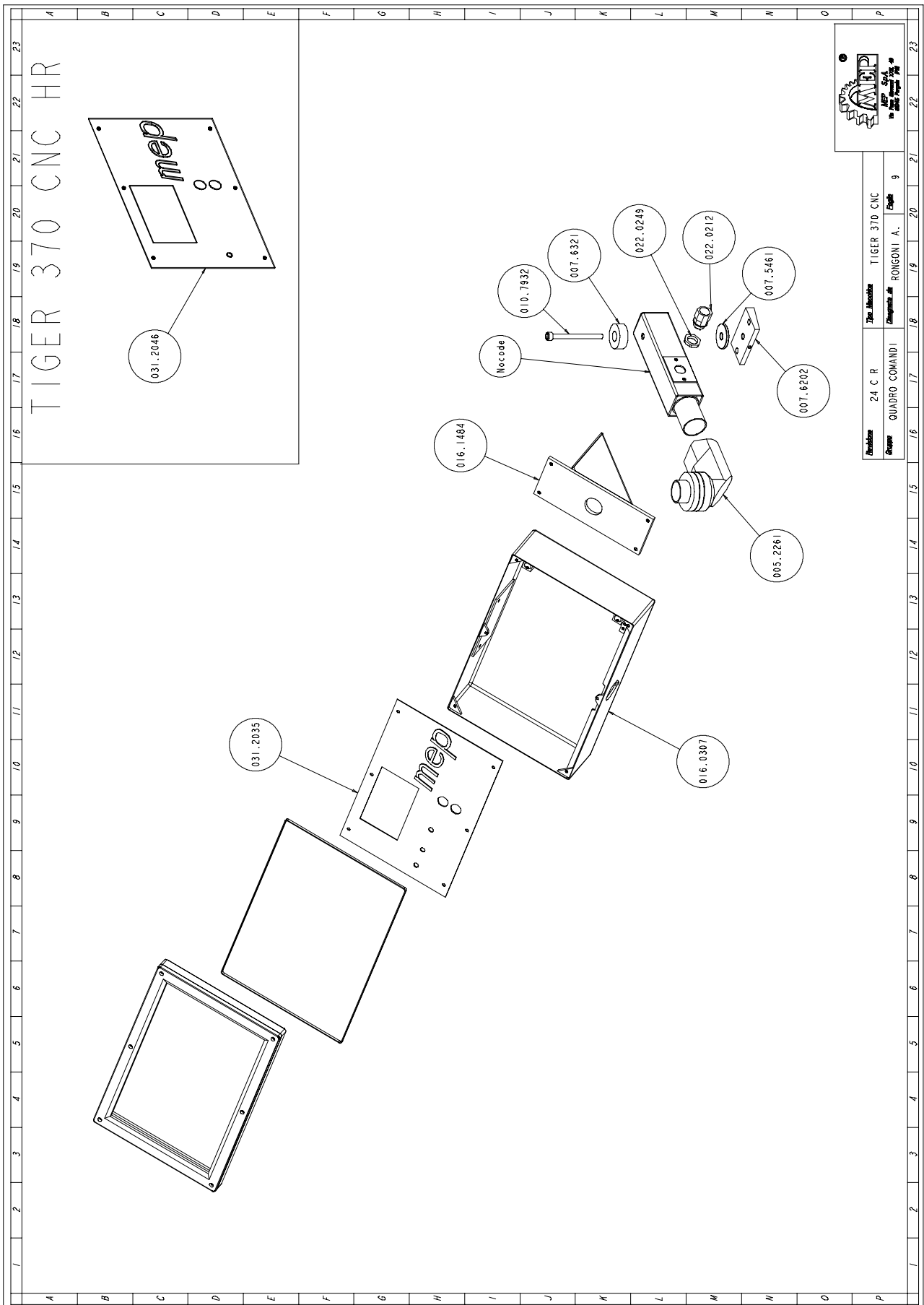

Model	24 C R	The Machine	TIGER 370 CNC
Operatie	QUADRO COMANDI	Componente di	RONCONI A. [English] 9



Art. Nr.	Benaming	M.	Hoeveelheid
005.2261	GIUNTO ANGOLO X QUADRO 497500	NR	1,000
007.5461	ROSETTA ASTA MOBILE SH 420 SE	NR	1,000
007.6202	PIASTRA FISSAGGIO ASTA MOBILE	NR	1,000
007.6321	ROSETTA BLOCCAGGIO ASTA MOBILE	NR	1,000
010.7932	VITE TCEI 10 X 110	NR	1,000
016.0235	ASTA MOBILE X CONSOLLE TI 370	NR	1,000
016.0307	QUADRO COMANDI MEP-E	NR	1,000
016.1484	STAFFA FISSAGGIO CONSOLLE SH 4	NR	1,000
022.0212	RACCORDO RAPIDO SEM PG 16	NR	1,000
022.0249	DADO POLIAM.HUMMEL 1.262.1600.	NR	1,000
031.2046	CONSOLLE PROGRAMMAZIONE	NR	1,000

Veiligheidsstang groep

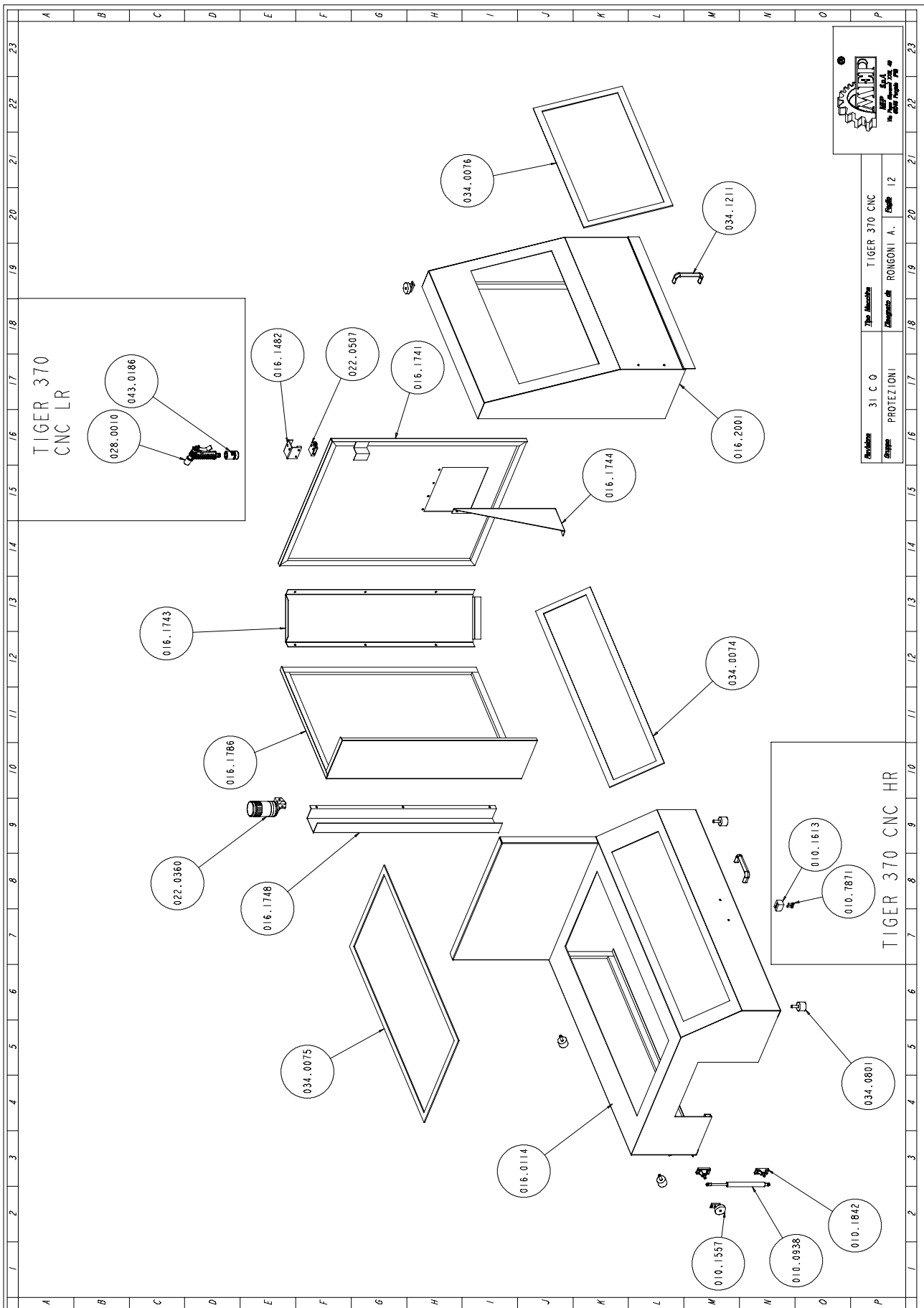

Art. Nr.	Benaming	M.	Hoeveelheid
010.0938	MOLLA GAS 120MM.	NR	1,000
010.1557	STAFFA COMANDO F.C.PROTEZIONE	NR	2,000
010.1613	TASSELLO X BLOCCAGGIO COPERCHI	NR	1,000
010.1842	SUPPORTO MASCHIO X MOLLA A GAS	NR	2,000
010.7871	VITE TCEI 6 X 20	NR	2,000
016.0114	CARTER ALIMENTATORE TI 370 N.T	NR	1,000
016.1482	STAFFA FISSAGGIO FINECORSIA SPO	NR	1,000
016.1741	PROTEZIONE LATERALE TI 370	NR	1,000
016.1743	PROTEZIONE ANGOLO TI 370	NR	1,000
016.1744	RINFORZO PROTEZIONE LATERALE T	NR	1,000
016.1748	PROTEZIONE CAVI TI 370 CNC	NR	1,000
016.1786	PROTEZIONE POSTERIORE TI 370 C	NR	1,000
016.2001	SPORTELLO PROTEZIONE MACCHINA	NR	1,000
022.0360	LAMPEGGIANTE	NR	1,000
022.0507	FINECORSIA D4C-1G02 1M	NR	1,000
034.0074	PROTEZ.LEXAN CARTER ALIM.FRONT	NR	1,000
034.0075	PROTEZIONE LEXAN CARTER ALIMEN	NR	1,000
034.0076	PROTEZIONE LEXAN X SPORTELLO M	NR	1,000
034.0801	ARRESTO ELASTICO P 40/30	NR	4,000
034.1211	MANIGLIA GN-565-20-128.SW	NR	2,000