

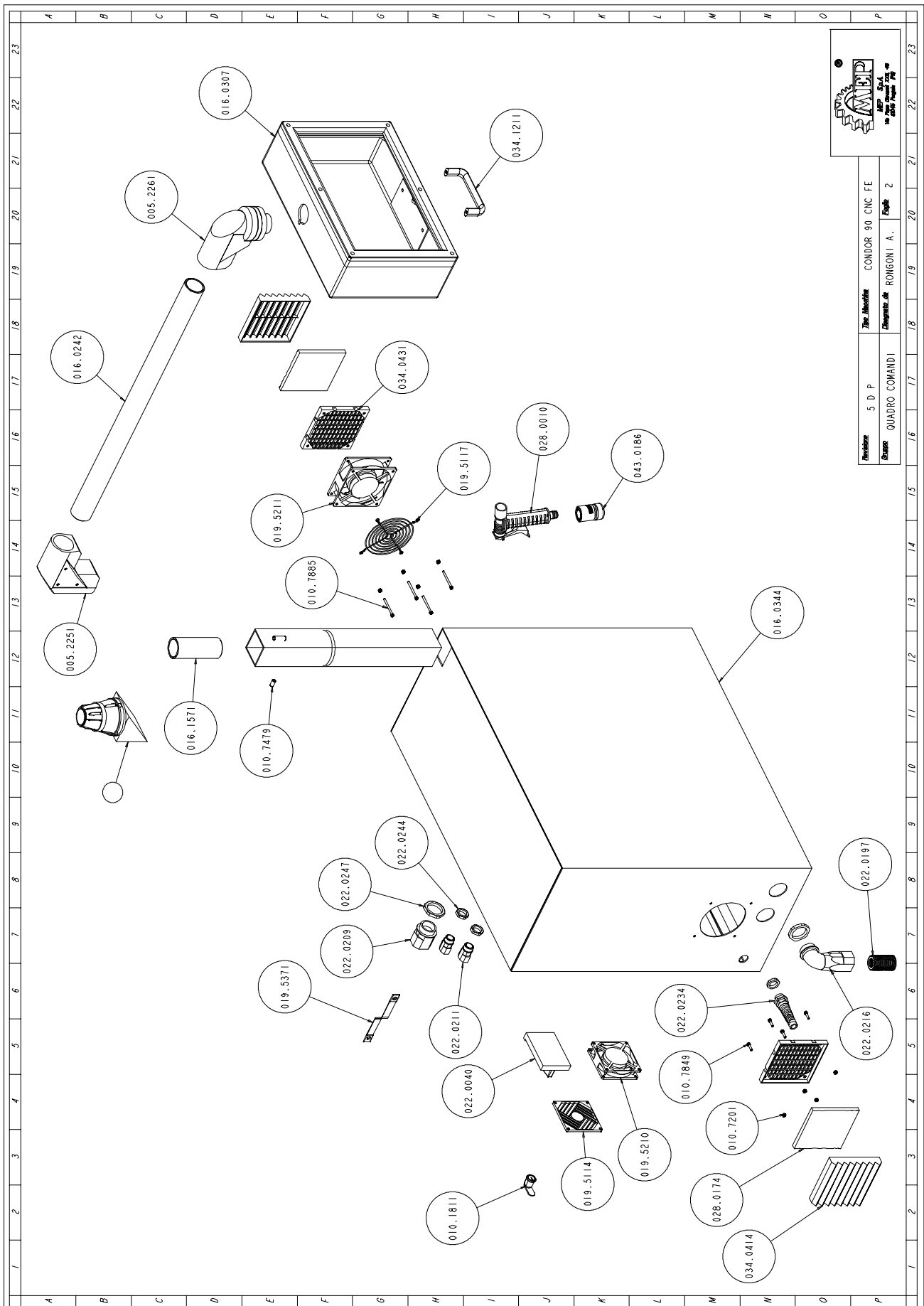

Art. Nr.	Benaming	M.	Hoeveelheid
010.1201	VITERIA E BULLONERIA	NR	2,000
010.1835	SET ATTACCHI 117.4.12.P AX-CNC	NR	2,000
010.7229	DADO AUTOBLOCCANTE M8	NR	2,000
010.7603	RONDELLA DIAM. 6	NR	5,200
010.7830	VITE BUTON 5 X 10	NR	2,000
010.7868	VITE TCEI 6 X 12	NR	5,000
010.7870	VITE TCEI 6 X 16	NR	2,000
013.0178	PIEDISTALLO CN 90 CNCFE	NR	1,000
016.1197	PANNELLO CABL.APP.PN.SH 320 AX 60Ø	NR	1,000
016.1488	STAFFA FILTRO PER NEBULIZZATORE	NR	1,000
019.5391	FASCETTA MINUS GT	NR	2,000
022.0211	RACCORDO RAPIDO SEM PG 13,5	NR	1,000
022.0216	RACCORDO POLIAMMIDE PA6 90Ø NERO	NR	1,000
022.0231	PRESSACAVO IN OTTONE 3/8 BM 2451	NR	1,000
022.0232	PRESSACAVO IN OTTONE 1/4 BM 2450	NR	6,000
022.0241	DADO IN OTTONE BM 2461 3/8	NR	1,000
022.0242	DADO IN OTTONE BM 2460 1/4	NR	6,000
022.0244	CONTRODADO 3217B GRIGIO PG 13	NR	1,000
022.0247	DADO POLIAM.HUMMEL 1.262.2900.11	NR	1,000
022.0324	PASSACAVI 24 INC.MM.2.5	NR	1,000
028.0121	RACCORDO 3/8-17 CL 2601	NR	2,000
028.0157	TUBO RETINATO DIAM.13-19	MT	2,000
028.0231	ELET.60/150 220-230-240/380-415.50	NR	1,000
034.0402	VALVOLA DI FONDO	NR	1,000
034.0901	"TAPPO LIVELLO OLIO 1/2 ""GAS."	NR	1,000
034.0905	"TAPPO OLIO TAO/3 1/2"" NERO"	NR	1,000
034.1112	VOLANTINO DIAM.40 M8	NR	2,000
034.1451	CATENA PORTACAVI E17.04.63.0	MT	1,000
043.0159	BLOCCO VALVOLE DA 3	NR	1,000
043.0198	ATTACCO A GOMITO GIREV.4X1/4 CL6521	NR	1,000
043.0204	ATTACCO A GOMITO 8X1/4 - CL 6521	NR	4,000
043.0205	ATTACCO A ESAGONO 8X1/4 - CL 6510	NR	1,000
043.0206	ATTACCO A ESAGONO 4X1/8 - CL 6511	NR	8,000
043.0222	RACCORDO A CROCE CL 2033 1/4	NR	1,000
043.0229	RIDUZIONE MF 1/4 - CL 2520	NR	2,000
043.0269	RACCORDO DIRITTO CL 1500 6/4 1/8	NR	1,000
043.0275	NIPPLO CONICO A2-1/4 - CL 2500	NR	2,000
043.0280	MANICOTTO 1/4 M 4/4 - CL 2543	NR	2,000
043.0282	MANICOTTO 3/8	NR	1,000
043.0290	INNESTO RAPIDO 1/4 GHIOTTO 13/A	NR	4,000
043.0301	TUBO RILSAN 8X6 NERO COD.17257181	MT	7,000
043.0302	TUBO RILSAN 4X2.7 BIANCO C.17257162	MT	5,000
043.0472	SILENZIATORE 1/4- PLASTICA	NR	4,000
043.0552	MANOMETRO DIAM. 40	NR	2,000
043.0564	FR 1/4 20-08	NR	1,000
043.0580	REGOLATORE MR 1/4 O-8	NR	1,000
043.0601	VALVOLA VMS 114-1/4 08	NR	1,000

## Bedieningspaneel groep



Revision	5 D P	The Machine	CONDOR 90 CNC FE
Group	QUADRO COMANDI	Disegnato da	RONGONI A.
		Esigete	2



Art. Nr.	Benaming	M.	Hoeveelheid
005.2251	ANGOLO X QUADRO COMANDI	NR	1,000
005.2261	GIUNTO ANGOLO X QUADRO 497500	NR	1,000
010.1201	VITERIA E BULLONERIA	NR	1,000
010.1811	SERRATURA ART 1511 MM.21	NR	1,000
010.7201	DADO M4	NR	8,000
010.7204	DADO M8	NR	2,000
010.7479	GRANO VCE PUNTA PIANA 8 X 16	NR	1,000
010.7849	VITE TCEI 4 X 16	NR	4,000
010.7885	VITE TCEI 4 X 50	NR	4,000
016.0242	ASTA MOBILE X CONSOLLE	NR	1,000
016.0307	QUADRO COMANDI MEP-E	NR	1,000
016.0344	QUADRO ELETTRICO	NR	1,000
016.1571	MANICOTTO X ANGOLO COMMANDER	NR	1,000
019.5114	COPRIVENTOLA X ALIMENTAT.SA 140	NR	1,000
019.5117	COPRIVENTOLA	NR	1,000
019.5210	VENTOLA X ALIMENTATORE SA 140	NR	1,000
019.5211	VENTOLA 4715MS 23TB	NR	1,000
019.5371	TRECCE X SPORTELLI	NR	1,000
022.0040	COMANDO BLOCCOPORTA 3ZV19260B	NR	1,000
022.0197	GUAINA POLYFLEX NW 29- 1200291	MT	1,000
022.0209	RACCORDO RAPIDO SEM 29 ART.3800296	NR	1,000
022.0211	RACCORDO RAPIDO SEM PG 13,5	NR	2,000
022.0216	RACCORDO POLIAMMIDE PA6 90Ø NERO	NR	1,000
022.0234	PRESSACORDONE 3246 NERO PG 13,5	NR	1,000
022.0244	CONTRODADO 3217B GRIGIO PG 13	NR	3,000
022.0247	DADO POLIAM.HUMMEL 1.262.2900.11	NR	2,000
022.0361	LAMPADA MICROLUX C.24 V. CON SUONO	NR	1,000
028.0010	PISTOLA	NR	1,000
028.0174	FILTRO M12R X VENTOLA	NR	2,000
034.0414	COPERCHIO ALETT. A12C-7032	NR	2,000
034.0431	BASE A12B - 7032	NR	2,000
034.1211	MANIGLIA GN-565-20-128.SW	NR	1,000
043.0186	RACCORDO FEMMINA 1/2 AQUASTOP	NR	1,000

### Vaste-tafel groep

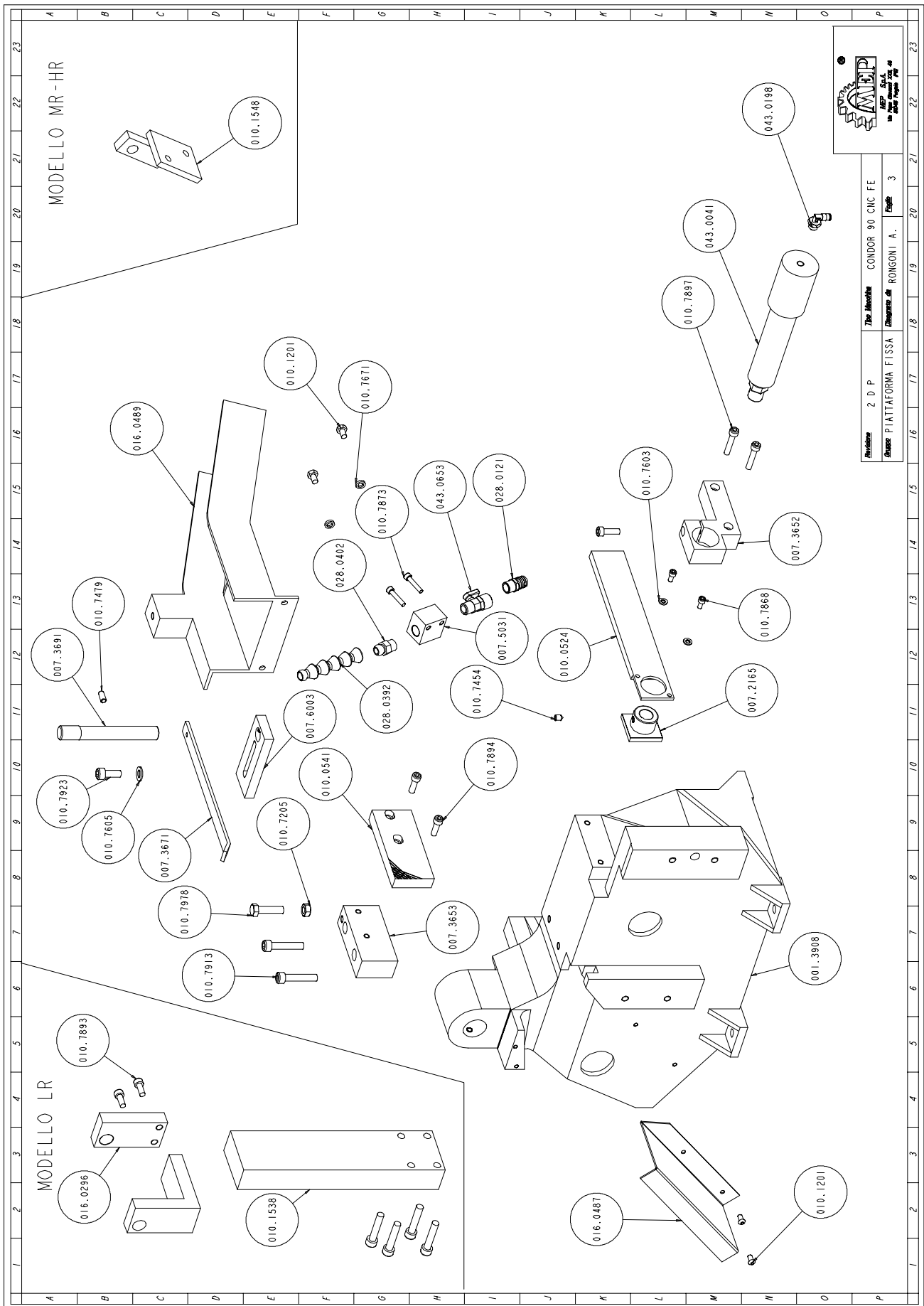

Art. Nr.	Benaming	M.	Hoeveelheid
001.3908	PIATTAFORMA FISSA CN 90 CNCFE M.959	NR	1,000
007.2165	SUPPORTO GANASCIA MORSA	NR	1,000
007.3652	SUPPORTO GANASCIA ANTIBAVA CN 90	NR	1,000
007.3653	SUPPORTO GANASCIA FISSA DESTRA CN90	NR	1,000
007.3671	PIASTRA PREMIBARRA CN 90	NR	1,000
007.3691	PERNO X PREMIBARRA CN 90	NR	1,000
007.5031	SQUADRETTO X LIQUIDO PIANO GIREVOLE	NR	1,000
007.6003	SUPPORTO PERNO PREMIBARRA CB 6000	NR	1,000
010.0524	GANASCIA ANTIBAVA MOBILE CN 90	NR	1,000
010.0541	GANASCIA MORSA DESTRA CN 90	NR	1,000
010.1201	VITERIA E BULLONERIA	NR	4,000
010.1538	STAFFA SUPPORTO CILINDRO CN 90	NR	1,000
010.1548	STAFFA AGGANCIO CILINDRO CONDOR	NR	1,000
010.7205	DADO M10	NR	1,000
010.7454	GRANO VCE P.CON. 8 X 8	NR	1,000
010.7479	GRANO VCE PUNTA PIANA 8 X 16	NR	1,000
010.7603	RONDELLA DIAM. 6	NR	2,000
010.7605	RONDELLA DIAM. 10	NR	1,000
010.7671	RODELLA SPESSORE DIAM. 8 X 3	NR	2,000
010.7868	VITE TCEI 6 X 12	NR	2,000
010.7873	VITE TCEI 6 X 30	NR	2,000
010.7893	VITE TCEI 8 X 20	NR	2,000
010.7894	VITE TCEI 8 X 25	NR	3,000
010.7897	VITE TCEI 8 X 40	NR	2,000
010.7913	VITE TCEI 10 X 50	NR	6,000
010.7923	VITE TCEI 10 X 25	NR	1,000
010.7978	VITE TE 10 X 40	NR	1,000
016.0296	STAFFA ESTERNA CILINDRO	NR	1,000
016.0487	GUIDA SCARICO TRUCIOLI SH 330 AXI S	NR	1,000
016.0489	GUIDA SCARICA PEZZI CN 90	NR	1,000
028.0121	RACCORDO 3/8-17 CL 2601	NR	1,000
028.0392	TUBO LOOC LINE BZ44BO.0350 3/8	MT	1,000
028.0397	UGELLO 0 12 BZ 4480.0313	NR	1,000
028.0402	RACCORDO 3/8 BZ 4480.0305	NR	1,000
043.0041	CILINDRO MORSE 50X10 0 40 L.150 D.E	NR	1,000
043.0198	ATTACCO A GOMITO GIREV.4X1/4 CL6521	NR	1,000
043.0653	RUBINETTO M/F 3/8 CL 6310	NR	1,000



Art. Nr.	Benaming	M.	Kvantum
002.0052	.STAFFA POSTERIORE CN 90	NR	1,000
002.0063	.CHIOCCIOLA MORSA DI TAGLIO CN 90	NR	1,000
007.3632	BOCCOLA FILETTATA TPN 24X5	NR	1,000
007.3713	GANASCIA MORSA CN 90 CNCFE	NR	2,000
007.3741	GUIDA CHIOCCIOLA CN 90 CNCFE	NR	2,000
007.3761	BARRA APPOGGIA PEZZI DESTRA CN 90	NR	2,000
007.4223	STAFFA ANTERIORE	NR	1,000
007.4224	STAFFA REGOLAZIONE ALIMENTATORE	NR	2,000
007.4251	BRONZINA MORSA	NR	2,000
010.0233	VITE MORSA 414X24 FILETTO SINISTRO	NR	1,000
010.1515	STAFFA FIX F.C.MORSA DI TAGLIO	NR	1,000
010.7205	DADO M10	NR	2,000
010.7410	GRANO VCE P.CIL. 8 X 16	NR	1,000
010.7454	GRANO VCE P.CON. 8 X 8	NR	1,000
010.7455	GRANO VCE P.CON. 8 X 10	NR	2,000
010.7467	GRANO VCE PUNTA PIANA 6 X 12	NR	1,000
010.7475	GRANO VCE P.PIANA 8 X 8	NR	1,000
010.7604	RONDELLA DIAM. 8	NR	1,000
010.7831	VITE BUTON 5 X 12	NR	2,000
010.7851	VITE TCEI 4 X 10	NR	2,000
010.7859	VITE TCEI 5 X 12	NR	4,000
010.7860	VITE TCEI 5 X 15	NR	6,000
010.7870	VITE TCEI 6 X 16	NR	2,000
010.7871	VITE TCEI 6 X 20	NR	4,000
010.7872	VITE TCEI 6 X 25	NR	8,000
010.7893	VITE TCEI 8 X 20	NR	5,000
010.7927	VITE TCEI 10 X 60	NR	4,000
010.7944	VITE TCEI 12 X 60	NR	4,000
010.7978	VITE TE 10 X 40	NR	2,000
016.0439	PROTEZIONE FINE C. MORSA DI TAGLIO	NR	1,000
022.0503	FINECORSIA CROUZET 83.123.018	NR	1,000
025.0203	ANELLO TENUTA 35X25X7	NR	1,000
034.0205	VOLANTINO VPRA/125 MR	NR	1,000
043.0044	CILINDRO VOLAMP.100-8 CIRCOL.	NR	1,000
043.0206	ATTACCO A ESAGONO 4X1/8 - CL 6511	NR	2,000
043.0302	TUBO RILSAN 4X2.7 BIANCO C.17257162	MT	2,000
090.5201	PARTICOLARI	NR	3,000



# Rollenbandgroep toevoerinrichting

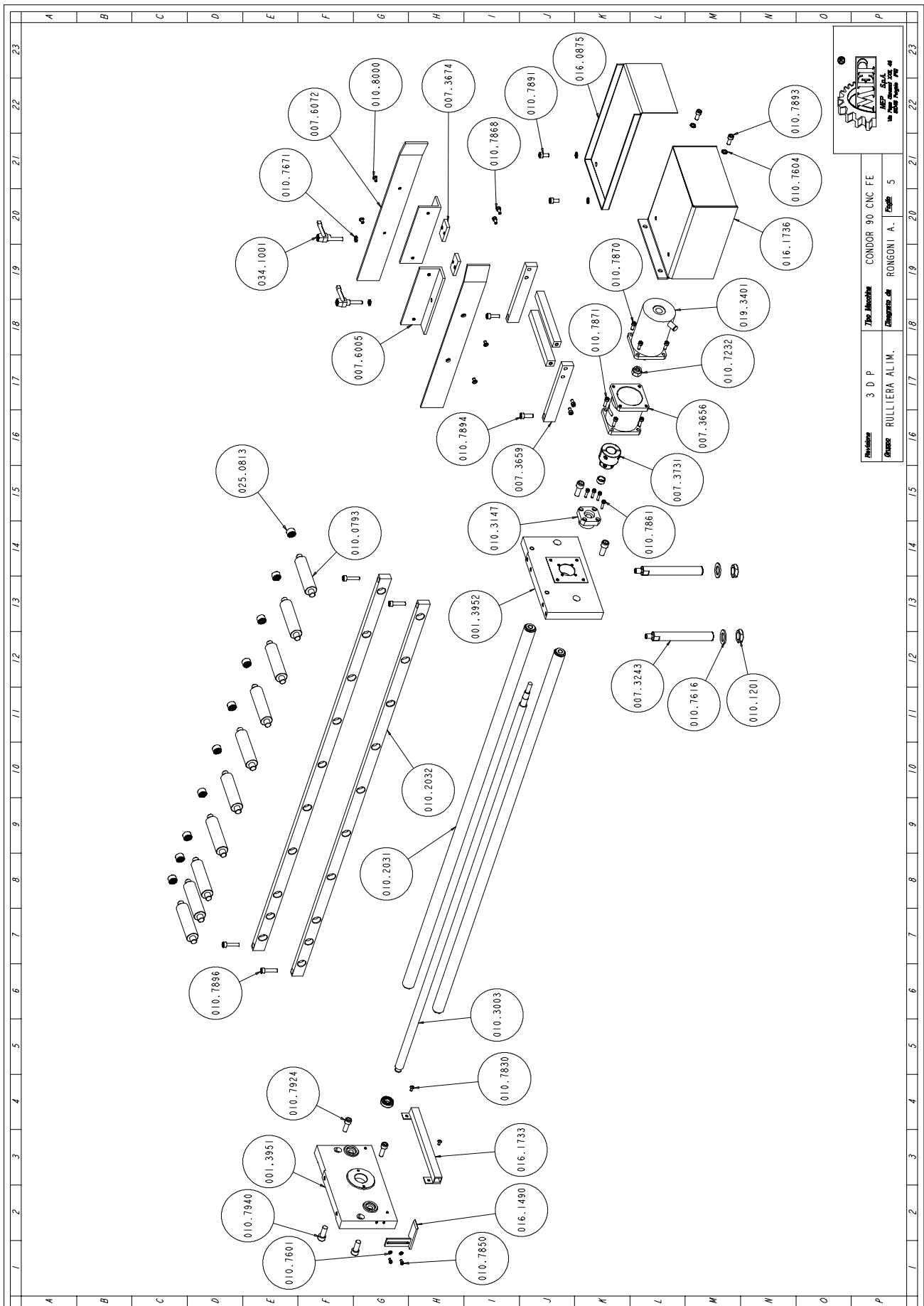

Revisione 3 D P	Tipo Macchine CONDOR 90 CNC FE
Disegnata da RULLIERA ALIM.	Disegnata da RONGONI A.
	Foglio 5

Art. NR.	Benaming	M.	Hoeveelheid
001.3951	STAFFA ANTERIORE ALIM	NR	1,000
010.2032	GUIDA RULLO ALIMENTATORE	NR	2,000
001.3952	STAFFA POSTERIORE ALIMENTATORE	NR	1,000
010.3147	SUPPORTO VITE RULLATA NSK	NR	1,000
007.3731	GIUNTO MOTORE ALIMENTATORE	NR	1,000
019.3401	MOTORE PP EWHOF	NR	1,000
010.2031	GUIDA CARRELLO	NR	2,000
025.0813	BOCCOLA RULLINI IMA HK 1512	NR	20,000
016.1490	STAFFA COMANDO MICROINTERRUTTORE	NR	1,000
007.3243	SUPPORTO ALIMENTATORE	NR	2,000
016.1733	PROTEZIONE CAVO FINECORSO	NR	1,000
010.7940	M12 X 30 TCEI	NR	4,000
010.7924	M10 X 30 TCEI	NR	2,000
010.7896	M8 X 35 TCEI	NR	4,000
010.7616	ROSETTA 21 X 37	NR	2,000
010.1201	DADO M20 BASSO	NR	2,000
010.7601	ROSETTA 4_1X9	NR	2,000
010.7850	M4 X 8 TCEI	NR	2,000
010.7830	M5 X 10 BUTTON	NR	2,000
016.1736	PROTEZIONE MOTORE ALIMENTATORE	NR	1,000
010.7604	ROSETTA 8 4 X 14	NR	4,000
010.7893	M8 X 20 TCEI	NR	2,000
016.0875	ADATTATORE CARICATORE CB 6000	NR	1,000
010.7891	M8 X 16 TCEI	NR	2,000
010.0793	RULLO ALIMENTATORE	NR	10,000
010.7861	M5 X 20TCEI	NR	4,000
010.3003	VITE RULLATA D20P40RS2040A20NSK	NR	1,000
010.7232	DADO AUTOBLOCCANTE M14	NR	1,000
010.7868	M6 X 12 TCEI	NR	8,000
007.3656	SUPPORTO MOTORE PASSO-PASSO ALIMENTATORE	NR	1,000
010.7870	M6 X 16 TCEI	NR	4,000
010.7871	M6 X 20 TCEI	NR	4,000
007.3659	STAFFA FISSAGGIO GUIDA CARICATORE DI BARRE	NR	2,000
034.1001	LEVA A SCATTO M8	NR	2,000
010.7671	ROSETTA 8 4X3	NR	2,000
007.6072	GUIDA BARRA CARICATORE DI BARRE	NR	2,000
010.8000	M6 X 8 TSPEI	NR	4,000
007.3674	PIASTRINO FISSAGGIO GUIDABARRA CARICATORE DI BARRE	NR	2,000
007.6005	SUPPORTO GUIDABARRA CARICATORE DI BARRE	NR	1,000
010.7894	M8 X 25 TCEI	NR	2,000

## Groep toevoerwagen

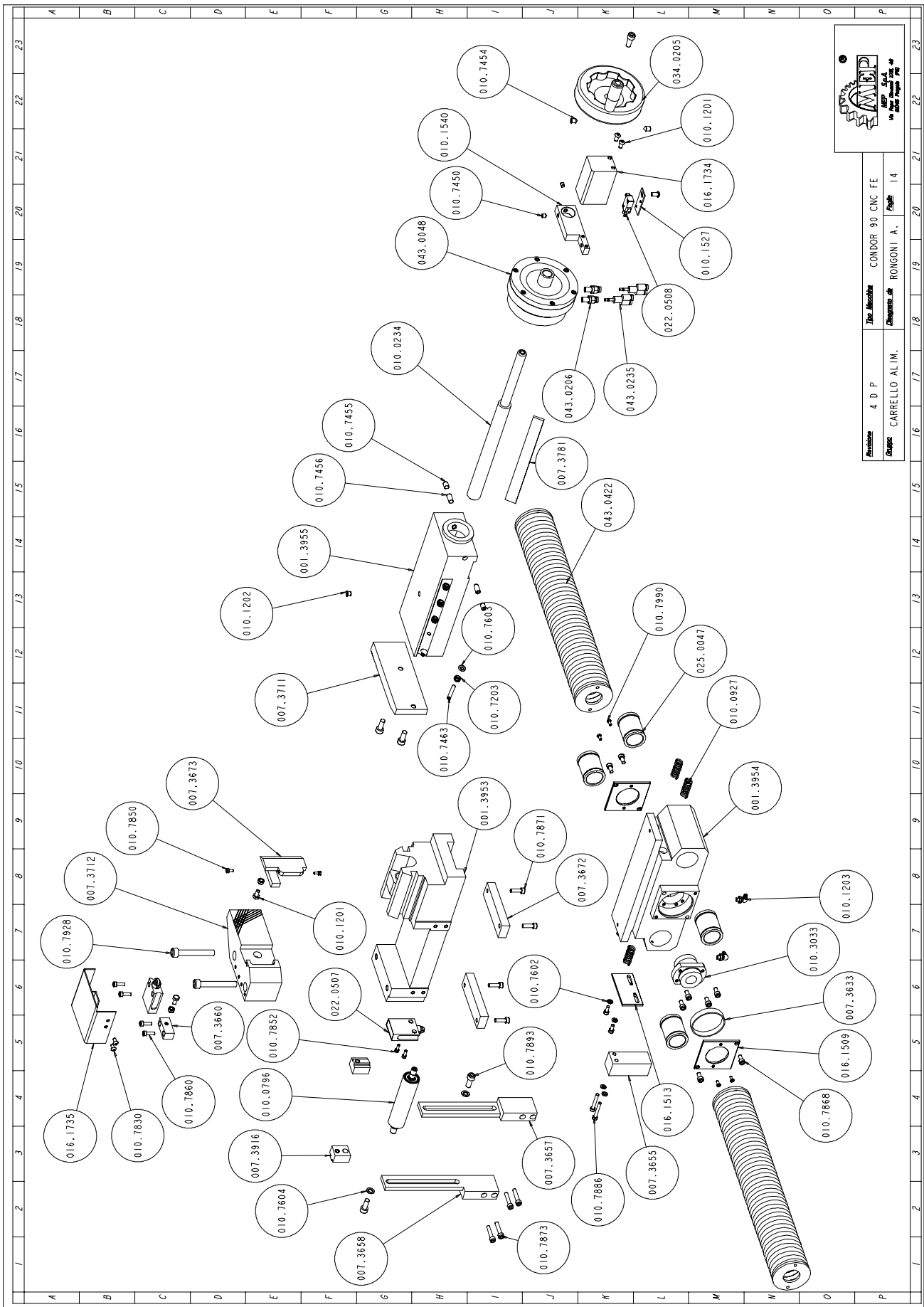

	
Revisione	4 D P
Dis. Macchine	CONDOR 90 CNC FE
Disegnata da	RONGONI A.
Scale	1:4

Art. NR.	Benaming	M.	Hoeveelheid
001.3953	SLITTA BASCULANTE ALIMENTATORE	NR	1,000
001.3954	CARRELLO ALIMENTATORE CN 90 CNCFE	NR	1,000
001.3955	.SCORREVOLE MORSA ALIMENTATORE	NR	1,000
007.3633	BOCCOLA CENTRAGGIO CHIOCCIOLA	NR	1,000
007.3655	SUPPORTO CATENA PORTACAVI CN 90	NR	1,000
007.3657	SUPPORTO RULLO PREMIBARRA ANTERIORE	NR	1,000
007.3658	SUPPORTO RULLO PREMIBARRA POSTERIORE	NR	1,000
007.3660	SUPPORTO BATTUTA TASTATORE	NR	1,000
007.3672	PIASTRA REGISTRAZIONE SLITTA BASCULANTE	NR	2,000
007.3673	PIASTRA COMANDO FINECORSO AVANZAMENTO	NR	1,000
007.3711	GANASCIA SCORREVOLE ALIMENTAT.CN 90	NR	1,000
007.3712	GANASCIA FISSA ALIMENTATORE CN 90	NR	1,000
007.3781	LARDONE MORSA	NR	1,000
007.3916	TASSELLO FIX RULLO SUPPLEMENTARE	NR	2,000
010.0234	VITE MORSA ALIMENTATORE 360X24 CN90	NR	1,000
010.0796	RULLO PREMIBARRA 0 30 COMPLETO ALIMENTATORE	NR	1,000
010.0927	MOLLA CARRELLO ALIMENTATORE	NR	4,000
010.1201	VITERIA E BULLONERIA	NR	5,000
010.1202	OLIATORE A SFERA DIAM. 8	NR	1,000
010.1203	OLIATORE A 90Ø 6X1	NR	2,000
010.1527	STAFFA FIX F.C.PRESENZA BARRA	NR	1,000
010.1540	STAFFA SUPPORTO FINECORSO PRESENZA	NR	1,000
010.3033	CHIOCCIOLA GY2040QS-HEZR CN 90	NR	1,000
010.7203	DADO M6	NR	7,000
010.7450	GRANO VCE P.CIL. 6 X 6	NR	2,000
010.7454	GRANO VCE P.CON. 8 X 8	NR	2,000
010.7455	GRANO VCE P.CON. 8 X 10	NR	2,000
010.7456	GRANO VCE P.CON. 8 X 16	NR	2,000
010.7463	GRANO VCE P.CON. 6 X 35	NR	5,000
010.7602	RONDELLA DIAM. 5	NR	4,000
010.7603	RONDELLA DIAM. 6	NR	5,000
010.7604	RONDELLA DIAM. 8	NR	2,000
010.7830	VITE BUTON 5 X 10	NR	2,000
010.7850	VITE TCEI 4 X 8	NR	2,000
010.7852	VITE TCEI 4 X 12	NR	6,000
010.7859	VITE TCEI 5 X 12	NR	6,000
010.7860	VITE TCEI 5 X 15	NR	8,000
010.7868	VITE TCEI 6 X 12	NR	8,000
010.7871	VITE TCEI 6 X 20	NR	4,000
010.7873	VITE TCEI 6 X 30	NR	4,000
010.7886	VITE TCEI 5 X 35	NR	2,000
010.7893	VITE TCEI 8 X 20	NR	5,000
010.7928	VITE TCEI 10 X 70	NR	2,000
010.7990	VITE TSPEI 4 X 8	NR	4,000
016.1509	STAFFA FIX SOFFIETTO CIRCOLARE	NR	2,000
016.1513	STAFFA FIX MICROINTERRUTTORE	NR	1,000
016.1734	PROTEZIONE FINECORSO PRESENZA BARRA	NR	1,000
016.1735	PROTEZIONE FINECORSO ALIMENTATORE	NR	1,000
022.0507	FINECORSO D4C-1G02 1M	NR	2,000
022.0508	FINECORSO V5B010 CB1	NR	1,000
025.0047	MANICOTTO A SFERA 0668.030.00 AL.	NR	4,000
025.0060	CUSCINETTO 6000 2Z	NR	2,000
025.0203	ANELLO TENUTA 35X25X7	NR	1,000
034.0205	VOLANTINO VPRA/125 MR	NR	1,000
043.0048	CILINDRO VOLAMPRESS 0 100 ALIMENTATORE	NR	1,000
043.0206	ATTACCO A ESAGONO 4X1/8 - CL 6511	NR	2,000
043.0235	BIFORCAZ. A Y TUBO 4MM. 24275320	NR	2,000
043.0422	SOFFIETTO CIRCOLARE ALIMENTATORE	NR	2,000
090.5201	PARTICOLARI	NR	3,000

# Veiligheidsstang-voor groep

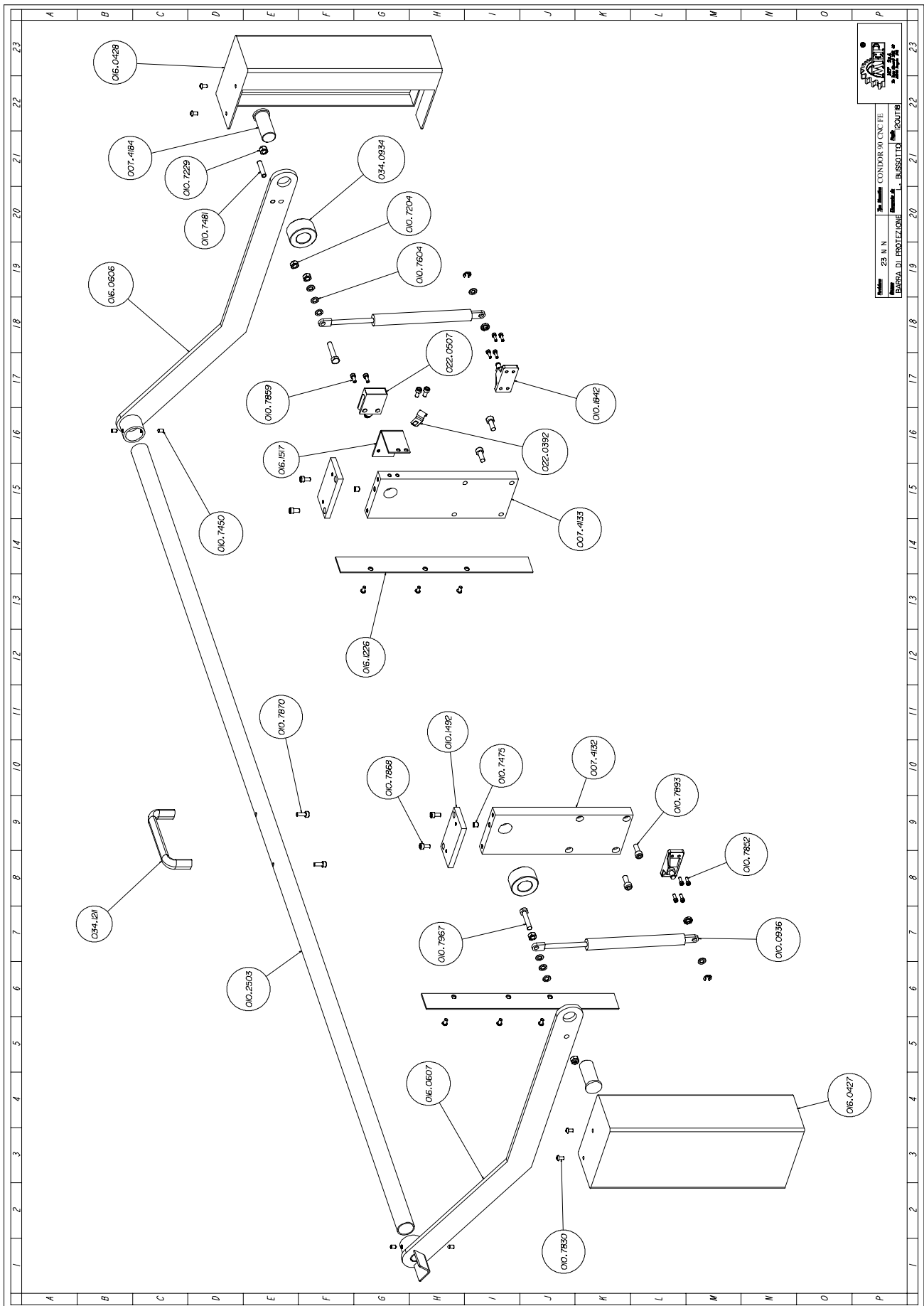

25 N N  
BARBA DI PROTEZIONE L. BUSSETTI S.p.A.  
CONDOR 90 CNC FE  
TECOUTI

<b>Art. Nr.</b>	<b>Benaming</b>	<b>M.</b>	<b>Hoeveelheid</b>
007.4132	SUPPORTO DX BARRA PROTEZIONE	NR	1,000
007.4133	SUPPORTO SX BARRA PROTEZIONE	NR	1,000
007.4184	PERNO BARRA PROTEZIONE	NR	2,000
010.0938	MOLLA GAS 120MM.1000N SH AX-AXI-CNC	NR	2,000
010.1492	STAFFA FIX BARRA PROTEZIONE	NR	2,000
010.1842	SUPPORTO MASCHIO X MOLLA A GAS	NR	2,000
010.2503	BARRA DI PROTEZIONE ANTERIORE	NR	1,000
010.7204	DADO M8	NR	3,000
010.7229	DADO AUT. M8	NR	2,000
010.7475	GRANO VCE P.PIANA 8 X 8	NR	2,000
010.7481	GRANO VCE PUNTA PIANA 8 X 35	NR	1,000
010.7603	RONDELLA DIAM. 6	NR	2,000
010.7604	RONDELLA DIAM. 8	NR	8,000
010.7830	VITE BUTON 5 X 10	NR	10,000
010.7852	VITE TCEI 4 X 12	NR	8,000
010.7859	VITE TCEI 5 X 12	NR	2,000
010.7868	VITE TCEI 6 X 12	NR	6,000
010.7870	VITE TCEI 6 X 16	NR	2,000
010.7893	VITE TCEI 8 X 20	NR	4,000
010.7967	VITE TE 8 X 40	NR	2,000
016.0427	PROTEZIONE DX BARRA ALIMENTORE	NR	1,000
016.0428	PROTEZIONE SX BARRA ALIMENTORE	NR	1,000
016.0606	SUPPORTO BARRA DI PROTEZIONE SX	NR	1,000
016.0607	SUPPORTO BARRA DI PROTEZIONE DX	NR	1,000
016.1226	PIASTRINO CHIUSURA PROTEZ.DX-SX	NR	2,000
016.1517	STAFFA FIX F.C.BARRA PROTEZIONE	NR	1,000
022.0392	GRAFFETTE IN ACCIAIO DM 10-11	NR	1,000
022.0507	FINECORSO D4C-1G02 1M	NR	1,000
034.0934	TAPPO DISTANZ.BARRA PROTEZIONE	NR	2,000
034.1211	MANIGLIA GN-565-20-128.SW	NR	1,000

### Beschermingseenheid zijkant en achter

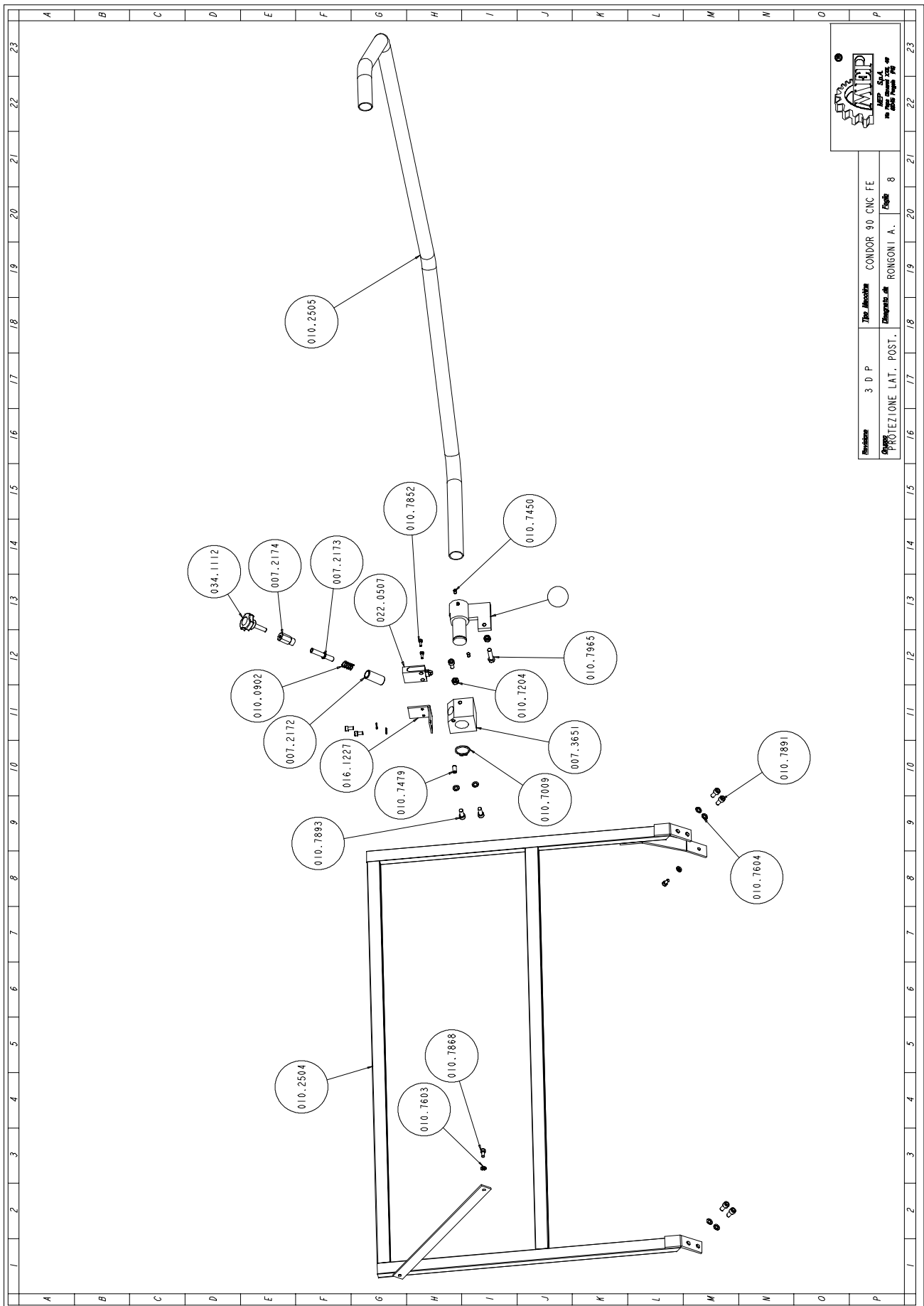

<b>Art. Nr.</b>	<b>Benaming</b>	<b>M.</b>	<b>Hoeveelheid</b>
007.2172	BUSSOLA	NR	1,000
007.2173	PERNO BLOCCAGGIO	NR	1,000
007.2174	GHIERA DI SPALLAMENTO	NR	1,000
007.3631	BOCCOLA FIX BARRA DI PROTEZIONE	NR	1,000
007.3651	SUPPORTO BOCCOLA FIX BARRA DI PRO-	NR	1,000
010.0902	MOLLE PUNTO FISSO TESTA	NR	1,000
010.2504	BARRA DI PROTEZIONE POSTERIORE CN90	NR	1,000
010.2505	BARRA DI PROTEZIONE LATERALE CN 90	NR	1,000
010.7009	ANELLO SEEGER DIAM. 30	NR	1,000
010.7204	DADO M8	NR	2,000
010.7450	GRANO VCE P.CIL. 6 X 6	NR	2,000
010.7479	GRANO VCE PUNTA PIANA 8 X 16	NR	1,000
010.7483	GRANO VCE PUNTA PIANA 8X50	NR	1,000
010.7603	RONDELLA DIAM. 6	NR	4,000
010.7604	RONDELLA DIAM. 8	NR	6,000
010.7852	VITE TCEI 4 X 12	NR	2,000
010.7868	VITE TCEI 6 X 12	NR	4,000
010.7891	VITE TCEI 8 X 16	NR	5,000
010.7893	VITE TCEI 8 X 20	NR	2,000
010.7965	VITE TE 8 X 35	NR	1,000
016.1227	.	NR	1,000
022.0507	FINECORSA D4C-1G02 1M	NR	1,000
034.1112	VOLANTINO DIAM.40 M8	NR	1,000



### Zaagbeugelgroep voor model LR

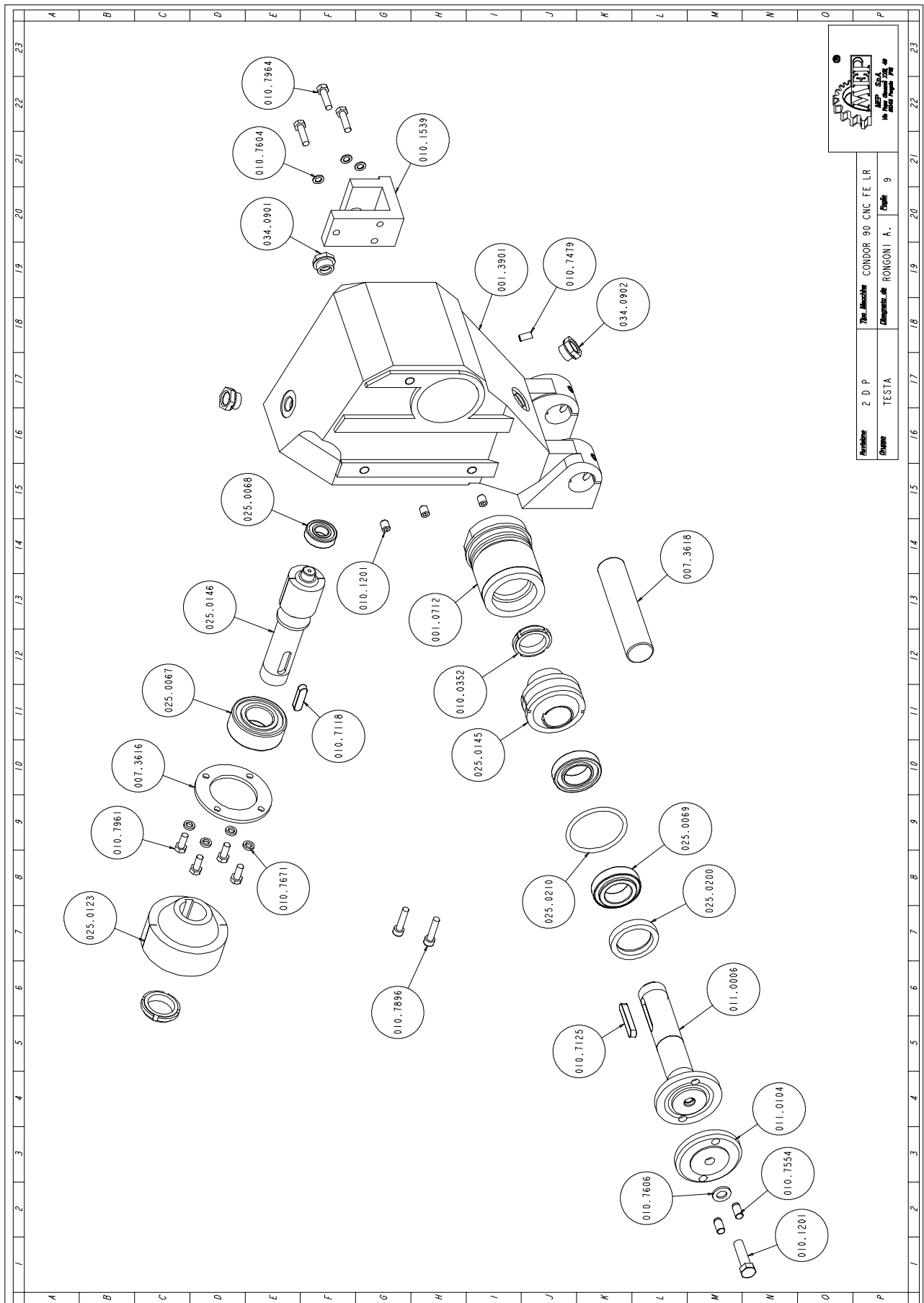

Art. Nr.	Benaming	M.	Hoeveelheid
001.0712	TAMPONE GRUPPO FRIZIONE	NR	1,000
001.3901	TESTA	NR	1,000
007.3616	GHIERA FIX CUSCINETTO	NR	1,000
007.3618	PERNO SUPPORTO SNODO TESTA	NR	1,000
010.0352	GHIERA AUTOBLOCCANTE 35X1,5	NR	2,000
010.1201	VITERIA E BULLONERIA	NR	4,000
010.1539	STAFFA AGGANCIAMENTO CILINDRO CN 90	NR	1,000
010.7118	CHIAVETTA 10 X 8 X 40	NR	1,000
010.7125	CHIAVETTA 10 X 8 X 56	NR	1,000
010.7479	GRANO VCE PUNTA PIANA 8 X 16	NR	1,000
010.7554	PERNO DI TRASCINAMENTO 10 X 20	NR	2,000
010.7604	RONDELLA DIAM. 8	NR	3,000
010.7606	RONDELLA DIAM. 12	NR	1,000
010.7671	RODELLA SPESSORE DIAM. 8 X 3	NR	4,000
010.7896	VITE TCEI 8 X 35	NR	2,000
010.7961	VITE TE 8 X 20	NR	4,000
010.7964	VITE TE 8 X 30	NR	3,000
011.0006	ALBERO PORTADISCO	NR	1,000
011.0104	FLANGIA ESTERNA	NR	1,000
025.0067	CUSCINETTO 3207	NR	1,000
025.0068	CUSCINETTO 6203	NR	1,000
025.0069	CUSCINETTO 32007X	NR	2,000
025.0123	INGRANAGGIO D.43055/53 ALBERO VITE	NR	1,000
025.0145	CORONA ELICOIDALE DIS. 86.06.002	NR	1,000
025.0146	ALBERO VITE SENZA FINE DIS.86.06.01	NR	1,000
025.0200	ANELLO TENUTA 62X45X10	NR	1,000
025.0210	ANELLO TENUTA OR 6275-69,21	NR	1,000
034.0901	"TAPPO LIVELLO OLIO 1/2 ""GAS."	NR	1,000
034.0902	"TAPPO OLIO SFP 1/2"" ROSSO"	NR	2,000

### Zaagbeugelgroep voor modellen MR en HR

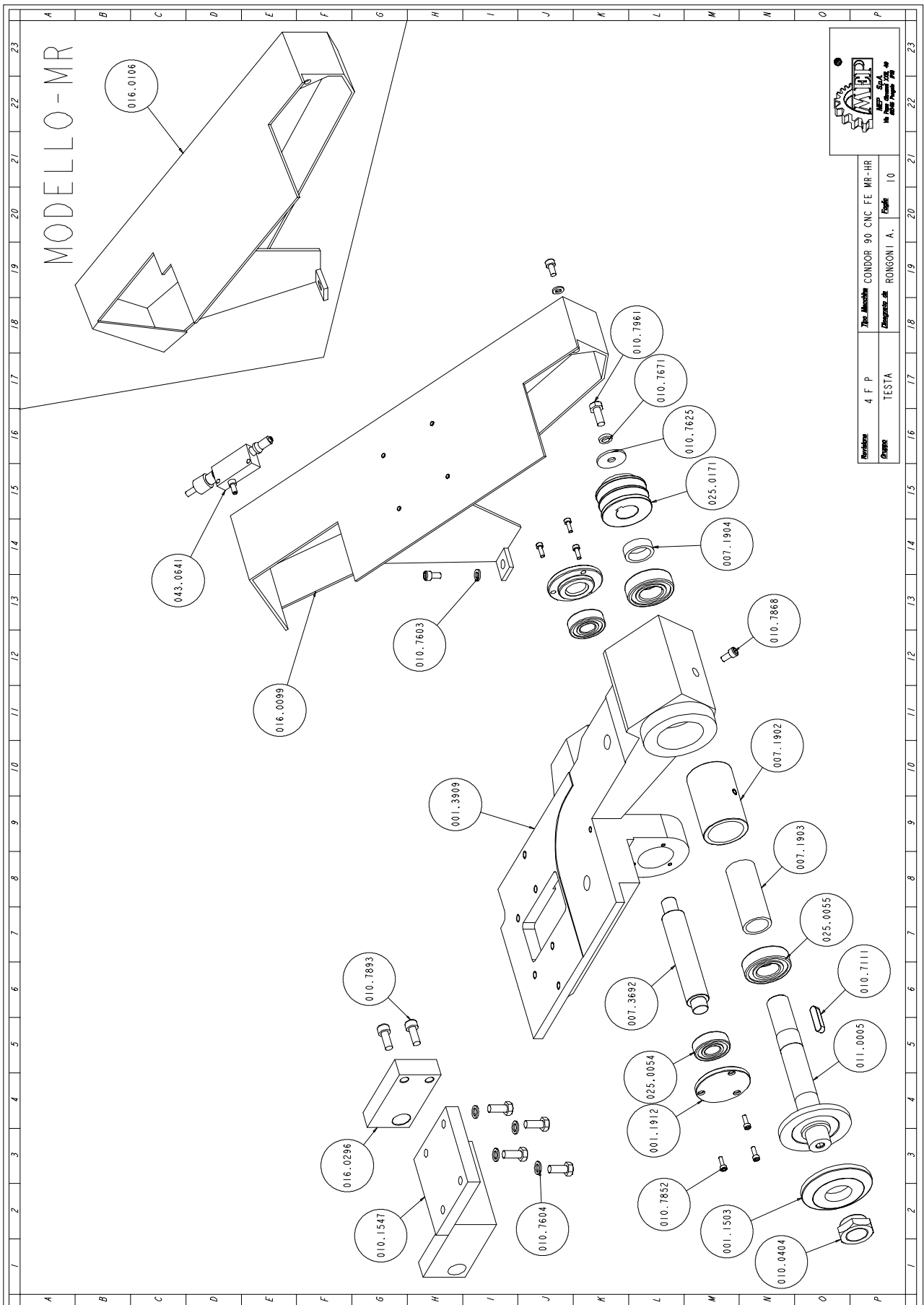

Particelle	4 F P	Titolo Macchine	CONDOR 90 CNC FE MR-HR
Disegno	TESTA	Disegnato da	ROGNONI A.
Scale	10	Verificato da	MEP

<b>Art. Nr.</b>	<b>Benaming</b>	<b>M.</b>	<b>Hoeveelheid</b>
001.1503	FLANGIA ESTERNA	NR	1,000
001.1912	COPERCHIO SNODO TESTA	NR	2,000
001.3909	BILANCIERE	NR	1,000
007.1902	DISTANZIALE CUSCINETTO ESTERNO	NR	1,000
007.1903	DISTANZIALE CUSCINETTO INTERNO	NR	1,000
007.1904	DISTANZIALE PULEGGIA	NR	1,000
007.3692	PERNO SUPPORTO SNODO TESTA CN 90	NR	1,000
010.0404	DADO ESAGONALE MM.25 P. 2	NR	1,000
010.1547	STAFFA SUPPORTO CILINDRO CONDOR 90	NR	1,000
010.7111	CHIAVETTA 8 X 7 X 32	NR	1,000
010.7603	RONDELLA DIAM. 6	NR	2,000
010.7604	RONDELLA DIAM. 8	NR	4,000
010.7625	RONDELLA DIAM. 8 X 32	NR	1,000
010.7671	RODELLA SPESSORE DIAM. 8 X 3	NR	1,000
010.7852	VITE TCEI 4 X 12	NR	6,000
010.7868	VITE TCEI 6 X 12	NR	3,000
010.7893	VITE TCEI 8 X 20	NR	2,000
010.7961	VITE TE 8 X 20	NR	5,000
011.0005	ALBERO PORTADISCO	NR	1,000
016.0099	CARTER CINGHIA	NR	1,000
016.0296	STAFFA ESTERNA CILINDRO	NR	1,000
016.0106	CARTER CINGHIA PER CN90 MODELLO MR	NR	1,000
025.0054	CUSCINETTO 62.03 2Z	NR	2,000
025.0055	CUSCINETTO 62.05 2Z C3	NR	2,000
025.0171	PULEGGIA 50X2 SPZ FORO 24	NR	1,000
043.0641	NEBULIZZATORE A DEPR. T.7240201	NR	1,000

### Cartergroep schijf voor model LR

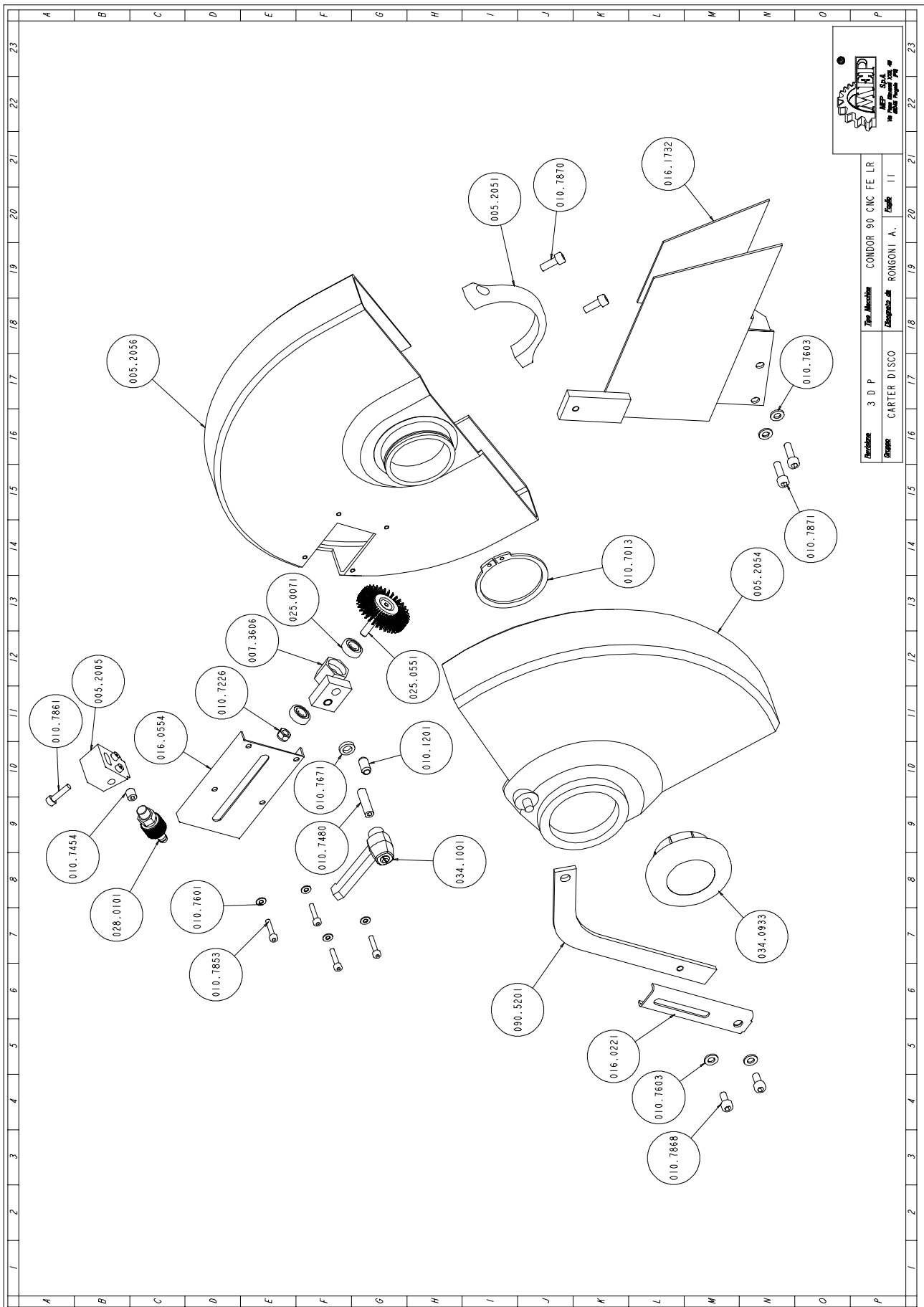

Modello	CONDOR 90 CNC FE LR
Descrizione	3 D P
Disegnato da	CARTER DISSCO
Disegnato da	RONGONI A.
Scale	1:1

<b>Art. Nr.</b>	<b>Benaming</b>	<b>M.</b>	<b>Hoeveelheid</b>
005.2005	SPRUZZATORE RUBINETTO	NR	1,000
005.2051	FASCETTA FISSAGGIO CARTER	NR	1,000
005.2054	PROTEZIONE DISCO	NR	1,000
005.2056	.CARTER DISCO	NR	1,000
007.3606	PIASTRINO PULILAMA COMPLETO	NR	1,000
010.1201	VITERIA E BULLONERIA	NR	1,000
010.7013	ANELLO SEEGER DIAM. 62	NR	1,000
010.7226	DADO AUTOBLOCCANTE M6	NR	1,000
010.7454	GRANO VCE P.CON. 8 X 8	NR	1,000
010.7480	GRANO VCE PUNTA PIANA 8 X 30	NR	1,000
010.7601	RONDELLA DIAM. 4	NR	4,000
010.7603	RONDELLA DIAM. 6	NR	4,000
010.7671	RODELLA SPESSORE DIAM. 8 X 3	NR	1,000
010.7853	VITE TCEI 4 X 20	NR	4,000
010.7861	VITE TCEI 5 X 20	NR	1,000
010.7868	VITE TCEI 6 X 12	NR	2,000
010.7870	VITE TCEI 6 X 16	NR	4,000
016.0554	GUIDA SPAZZOLA PULILAMA	NR	1,000
016.1732	PROTEZIONE FISSA CN 90	NR	1,000
025.0071	CUSCINETTO 626 2RS	NR	2,000
025.0551	SPAZZOLA PULILAMA 6X25 030 GG43	NR	1,000
028.0101	REGOLATORE PER RUBINETTO 8 X 1/4	NR	1,000
034.0933	TAPPO CARTER DISCO	NR	1,000
034.1001	LEVA A SCATTO 8 MA PK55	NR	1,000

### Cartergroep schijf voor modellen MR en HR

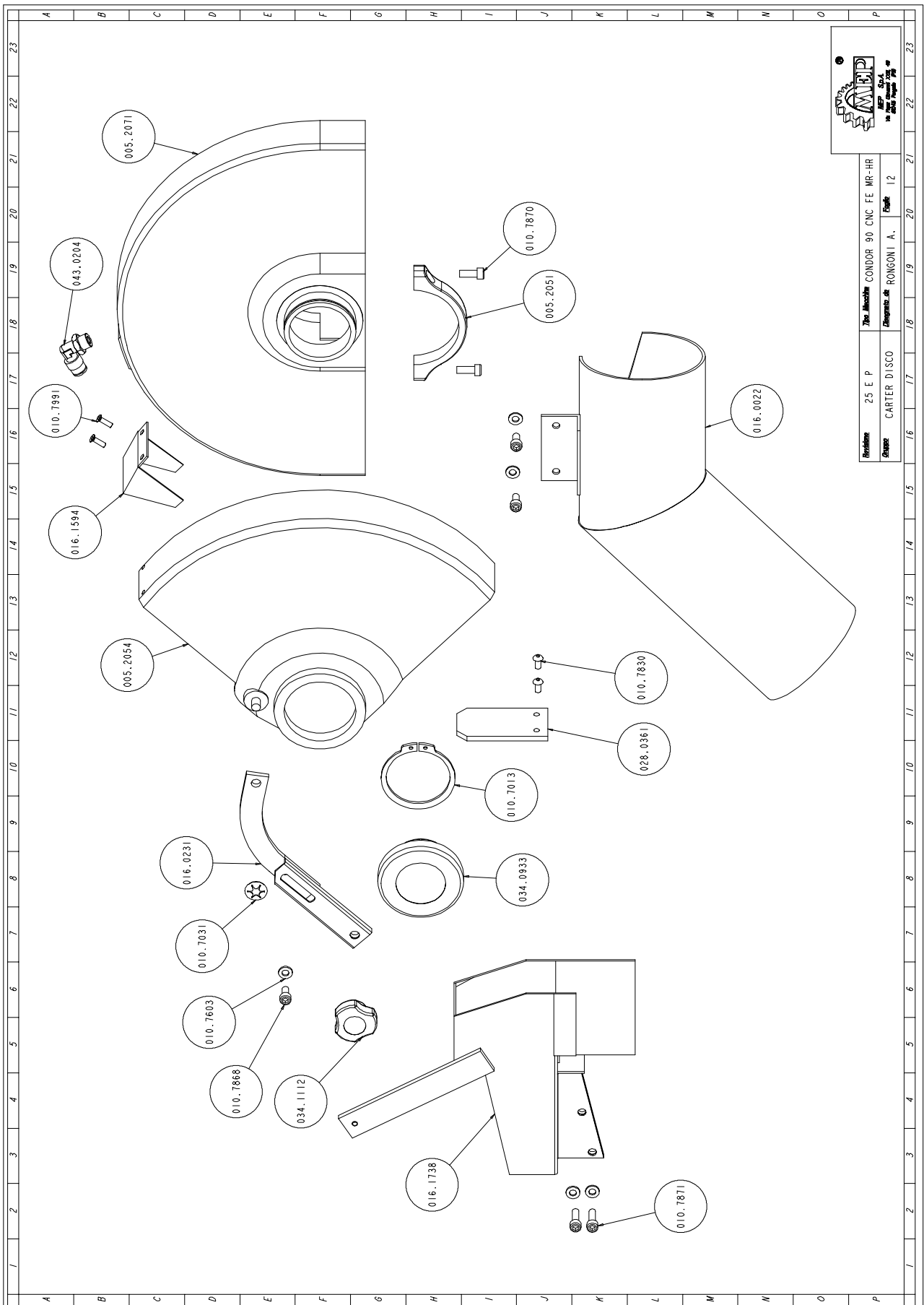

Model:	25 E P	Van Machine	CONDOR 90 CNC FE MR-HR
Ontwerp:	CARTER DISCO	Ontwerper:	RONGONI A.
		Blade:	12

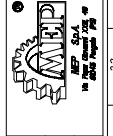

<b>Art. Nr.</b>	<b>Benaming</b>	<b>M.</b>	<b>Hoeveelheid</b>
005.2071	PROTEZIONE DISCO 0 300/315 MOD.174	NR	1,000
005.2051	FASCETTA FISSAGGIO CARTER	NR	1,000
005.2054	PROTEZIONE DISCO 300/315	NR	1,000
005.2071	.PROTEZIONE DISCO 0 300 CONDOR 90	NR	1,000
010.7013	ANELLO SEEGER DIAM. 62	NR	1,000
010.7031	ANELLO SEEGER SK DIAM. 8	NR	1,000
010.7603	RONDELLA DIAM. 6	NR	5,000
010.7830	VITE BUTON 5 X 10	NR	2,000
010.7868	VITE TCEI 6 X 12	NR	1,000
010.7870	VITE TCEI 6 X 16	NR	4,000
010.7871	VITE TCEI 6 X 20	NR	2,000
010.7991	VITE TSPEI 4 X 12	NR	2,000
016.0022	CONVOGLIATORE TRUCIOLI	NR	1,000
016.0231	ASTA COMANDO PROTEZIONE CN 90 HR-MR	NR	1,000
016.1594	PROLUNGA PROTEZIONE DISCO CN 90	NR	1,000
016.1738	.	NR	1,000
028.0361	RACCORDO IN GOMMA CARTER	NR	1,000
034.0933	TAPPO CARTER DISCO	NR	1,000
034.1112	VOLANTINO DIAM.40 M8	NR	1,000
043.0204	ATTACCO A GOMITO 8X1/4 - CL 6521	NR	1,000



### Motoreenheid voor model LR

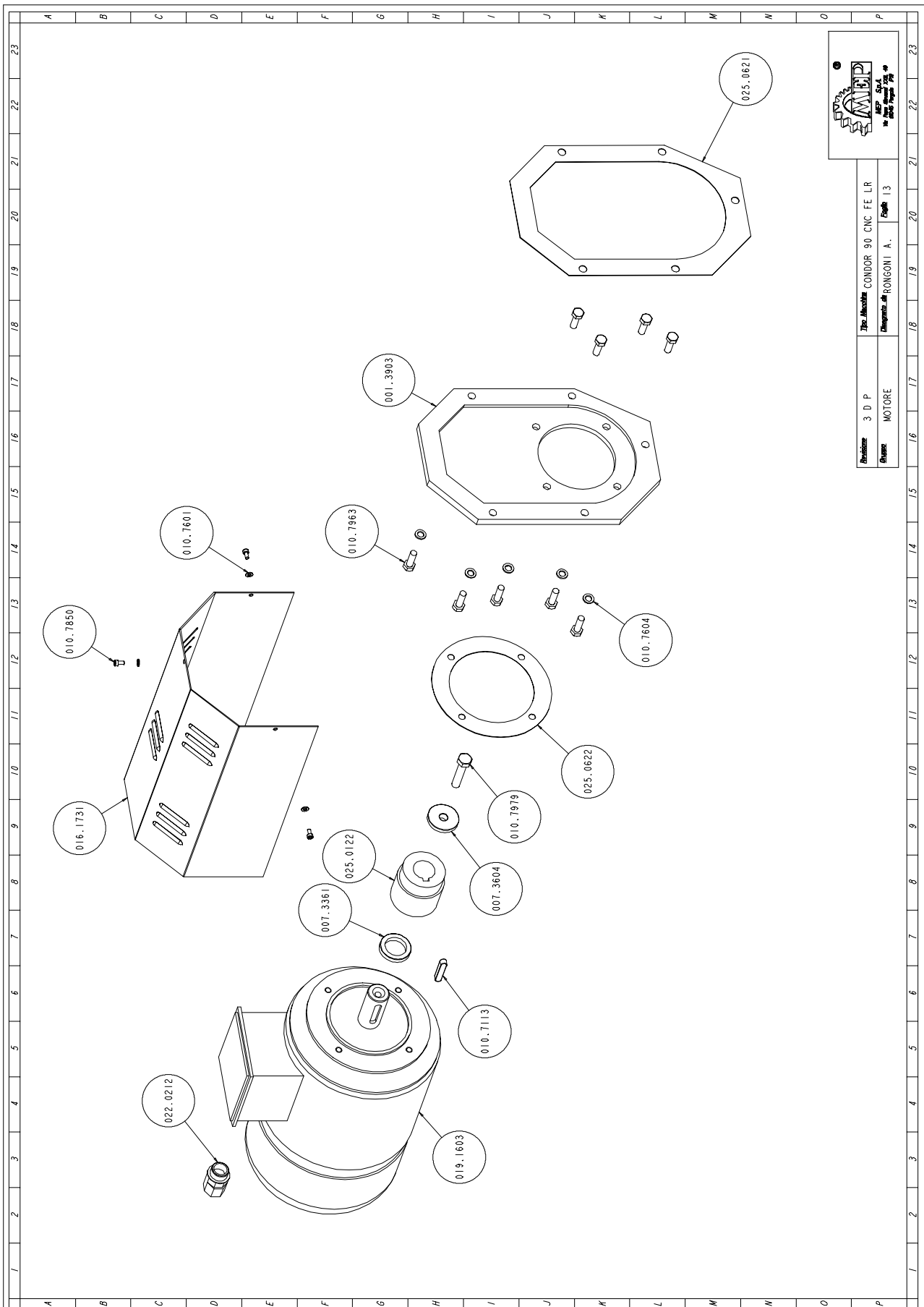

	
Revisie:	3 D P
Titel:	Motor Condor 90 CNC FE LR
Ontwerp:	CONDOR 90 RONGONI A. - Pagina 13

<b>Art. Nr.</b>	<b>Benaming</b>	<b>M.</b>	<b>Hoeveelheid</b>
001.3903	COPERCHIO TESTA	NR	1,000
007.3361	DISTANZIALE INGRANAGGIO MOTORE	NR	1,000
007.3604	RONDELLA FISSAGGIO INGRANAGGIO MOT.	NR	1,000
010.7113	CHIAVETTA 8 X 7 X 40	NR	1,000
010.7601	RONDELLA DIAM. 4	NR	3,000
010.7604	RONDELLA DIAM. 8	NR	5,000
010.7851	VITE TCEI 4 X 10	NR	3,000
010.7963	VITE TE 8 X 25	NR	9,000
010.7979	VITE TE 10 X 50	NR	1,000
016.1731	PROTEZIONE MOTORE TESTA CN 90	NR	1,000
019.1603	KW 1,8/1,3 3K100L4/8MB14 0 28 V.380	NR	1,000
022.0212	RACCORDO RAPIDO SEM PG 16	NR	1,000
025.0122	INGRANAGGIO D.43054/53 ALBERO MOT.	NR	1,000
025.0621	GUARNIZIONE TESTA	NR	1,000
025.0622	GUARNIZIONE MOTORE	NR	1,000

### Motoreenheid voor modellen MR en HR

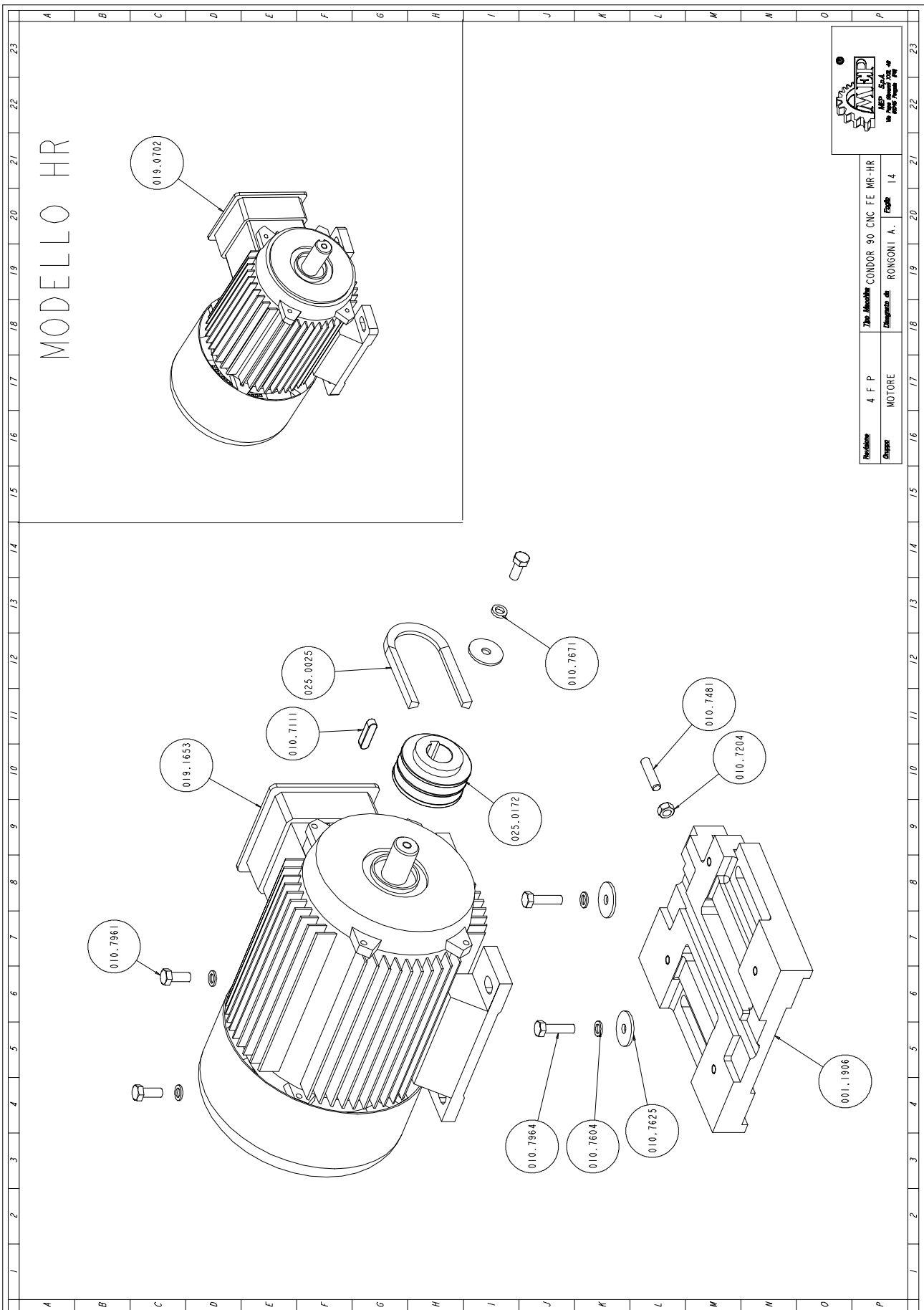

<b>Art. Nr.</b>	<b>Benaming</b>	<b>M.</b>	<b>Hoeveelheid</b>
001.1906	PIANA MOTORE	NR	1,000
010.7111	CHIAVETTA 8 X 7 X 32	NR	1,000
010.7204	DADO M8	NR	1,000
010.7481	GRANO VCE PUNTA PIANA 8 X 35	NR	1,000
010.7604	RONDELLA DIAM. 8	NR	6,000
010.7625	RONDELLA DIAM. 8 X 32	NR	3,000
010.7671	RODELLA SPESSORE DIAM. 8 X 3	NR	1,000
010.7961	VITE TE 8 X 20	NR	5,000
010.7964	VITE TE 8 X 30	NR	2,000
019.1653	KW 1,5 6P C100 B3 V.230-400 CN 90MR	NR	1,000
025.0025	CINGHIA SPZ 900 S.TX	NR	1,000
025.0172	PULEGGIA 60X2 SPZ FORO 24	NR	1,000

<b>Art. Nr.</b>	<b>Benaming</b>	<b>M.</b>	<b>Hoeveelheid</b>
001.1906	PIANA MOTORE	NR	1,000
010.7111	CHIAVETTA 8 X 7 X 32	NR	1,000
010.7204	DADO M8	NR	1,000
010.7481	GRANO VCE PUNTA PIANA 8 X 35	NR	1,000
010.7604	RONDELLA DIAM. 8	NR	6,000
010.7625	RONDELLA DIAM. 8 X 32	NR	3,000
010.7671	RODELLA SPESSORE DIAM. 8 X 3	NR	1,000
010.7961	VITE TE 8 X 20	NR	5,000
010.7964	VITE TE 8 X 30	NR	2,000
019.0702	HP 3 2P V220/380 C90R	NR	1,000
025.0025	CINGHIA SPZ 900 S.TX	NR	1,000
025.0172	PULEGGIA 60X2 SPZ FORO 24	NR	1,000

# Cilindergroep

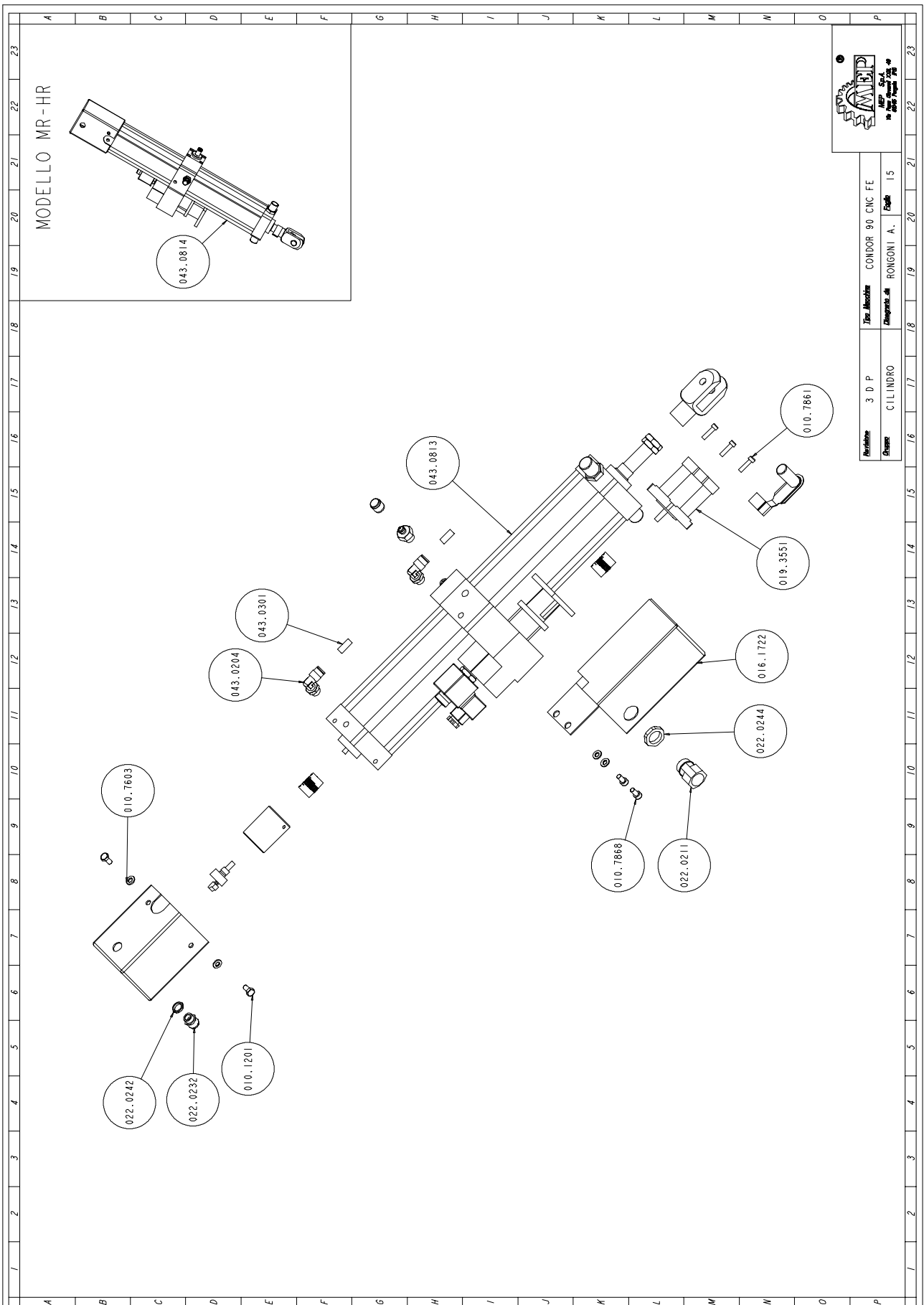

Art. Nr.	Benaming	M.	Hoeveelheid
010.1103	FORCELLA 16 X 1,5	NR	2,000
010.1201	VITERIA E BULLONERIA	NR	2,000
010.7603	RONDELLA DIAM. 6	NR	4,000
010.7861	VITE TCEI 5 X 20	NR	4,000
010.7868	VITE TCEI 6 X 12	NR	2,000
016.1722	PROTEZIONE CILINDRO	NR	1,000
019.3551	MOTORE MAE MOD.HY 200 2232 190B8CNC	NR	1,000
022.0046	POTENZIOMETRO 6639S-001-202	NR	1,000
022.0211	RACCORDO RAPIDO SEM PG 13,5	NR	1,000
022.0232	PRESSACAVO IN OTTONE 1/4 BM 2450	NR	1,000
022.0242	DADO IN OTTONE BM 2460 1/4	NR	1,000
022.0244	CONTRODADO 3217B GRIGIO PG 13	NR	1,000
022.0378	CONNETT.BOBINA VALV. RIGENERATRICE	NR	1,000
022.0615	BOBINA X VALVOLA RIGENERATRICE CIL.	NR	1,000
025.0252	ANELLO DK 40X8X20/4 PDF	NR	1,000
025.0876	GIUNTO WA 6-6 MM.28 X CILINDRO	NR	2,000
043.0204	ATTACCO A GOMITO 8X1/4 - CL 6521	NR	2,000
043.0813	UNITA' IDROPNEUMATICA 0 63 C.150	NR	1,000
043.5671	PROTEZIONE POTENZIOMETRO CILINDRO	NR	1,000
043.5681	SUPPORTO POTENZIOMETRO CILINDRO	NR	1,000
044.1251	VALVOLA RIGENERATRICE CILINDRO	NR	1,000
044.1257	VALVOLA DI CARICO CILINDRO	NR	1,000

Art. Nr.	Benaming	M.	Hoeveelheid
010.1103	FORCELLA 16 X 1,5	NR	2,000
010.1201	VITERIA E BULLONERIA	NR	2,000
010.7603	RONDELLA DIAM. 6	NR	4,000
010.7861	VITE TCEI 5 X 20	NR	4,000
010.7868	VITE TCEI 6 X 12	NR	2,000
016.1722	PROTEZIONE CILINDRO	NR	1,000
019.3551	MOTORE MAE MOD.HY 200 2232 190B8CNC	NR	1,000
022.0046	POTENZIOMETRO 6639S-001-202	NR	1,000
022.0211	RACCORDO RAPIDO SEM PG 13,5	NR	1,000
022.0232	PRESSACAVO IN OTTONE 1/4 BM 2450	NR	1,000
022.0242	DADO IN OTTONE BM 2460 1/4	NR	1,000
022.0244	CONTRODADO 3217B GRIGIO PG 13	NR	1,000
022.0378	CONNETT.BOBINA VALV. RIGENERATRICE	NR	1,000
022.0615	BOBINA X VALVOLA RIGENERATRICE CIL.	NR	1,000
025.0252	ANELLO DK 40X8X20/4 PDF	NR	1,000
025.0876	GIUNTO WA 6-6 MM.28 X CILINDRO	NR	2,000
043.0204	ATTACCO A GOMITO 8X1/4 - CL 6521	NR	2,000
043.0814	UNITA' IDROPNEUMATICA 0 63 C.200	NR	1,000
043.5671	PROTEZIONE POTENZIOMETRO CILINDRO	NR	1,000
043.5681	SUPPORTO POTENZIOMETRO CILINDRO	NR	1,000
044.1251	VALVOLA RIGENERATRICE CILINDRO	NR	1,000
044.1257	VALVOLA DI CARICO CILINDRO	NR	1,000