

Explosietekeningen

In het nu volgende deel zijn de explosietekeningen van de machine opgenomen. De tekeningen met hun volledige details kunnen helpen de machine beter te leren kennen.

Hoofd eenheid

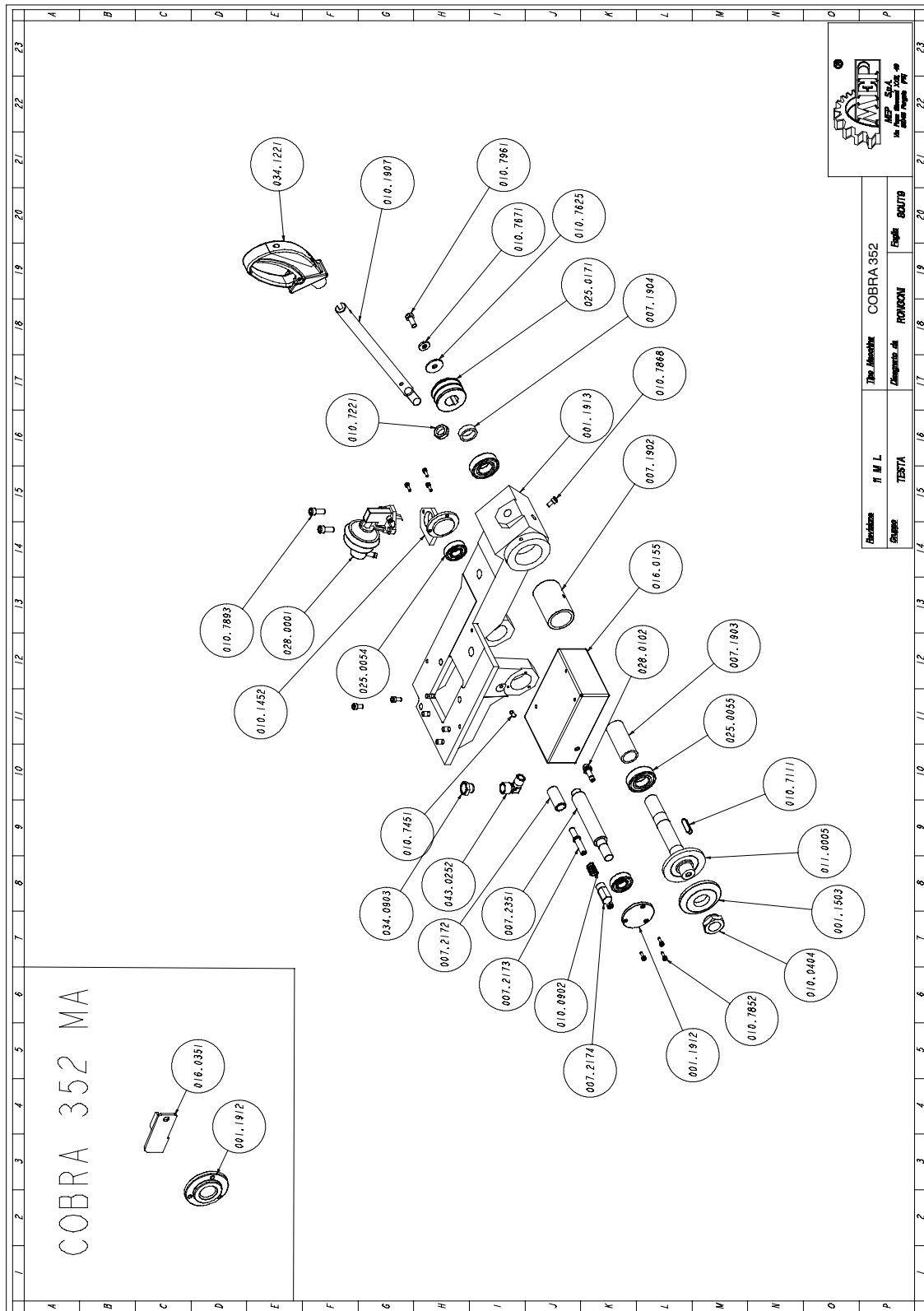

Art. Nr.	Benaming	M.	Hoeveelheid
001.1503	OUTER FLANGE CB 350 MOD.253	NR	1,000
001.1912	COVER CB 350 MOD.311	NR	2,000
001.1913	PLATFORM CB 350 MOD.312	NR	1,000
007.1902	EXT.BEARING SPACER CB 300/349/350	NR	1,000
007.1903	INT. BEARING SPACER CB 300/349/350	NR	1,000
007.1904	WHEEL SPACER CB 300/349/350	NR	1,000
007.2172	BUSHING CB 349-350 D	NR	1,000
007.2173	LOCKING PIN CB 349/350 D	NR	1,000
007.2174	RING NUT CB 349/350 D	NR	1,000
007.2351	HEAD PIVOT SUPPORT PIN CB 350	NR	1,000
010.0404	M M.25 P.HEX NUT 2 RA-CB 350	NR	1,000
010.0902	HEAD FIXED POINT SPRING	NR	1,000
010.1452	PUMP FIXING COVER CB 350	NR	1,000
010.1907	BT/NOT-AUS LEVER SC-CB-RA-TI	NR	1,000
010.7111	8 X 7 X 32 KEY	NR	1,000
010.7221	M16 LOW SCREW NUT	NR	1,000
010.7451	6 X 12 CONICAL POINT VCE GRUB SCREW	NR	1,000
010.7625	0 8 X 32 WASHER	NR	1,000
010.7671	THICKNESS WASHER DIAM. 8 X 3	NR	1,000
010.7852	TCEI 4 X 12 SCREW	NR	6,000
010.7868	TCEI 6 X 12 SCREW	NR	3,000
010.7893	TCEI 8 X 20 SCREW	NR	2,000
010.7961	TE 8 X 20 SCREW	NR	2,000
011.0005	BLADE SHAFT CB 349/350	NR	1,000
016.0155	TANK CB 350	NR	1,000
016.0351	VALVE CONTROL PLATE	NR	1,000
025.0054	BEARING 62.03 2Z	NR	2,000
025.0055	BEARING 62.05 2Z C3	NR	2,000
025.0171	WHEEL 50X2 SPZ HOLE 24	NR	1,000
028.0001	ALUMINIUM PUMP	NR	1,000
028.0102	JOINT WITH WASHER	NR	1,000
034.0903	3/8" GAS OIL LEVEL CAP	NR	1,000
043.0252	MF 3/8 CL 2020 ELBOW	NR	1,000
090.0271	COMPLETE MEP HANDLE	NR	1,000

Handgreep voor bediening Hoofd eenheid

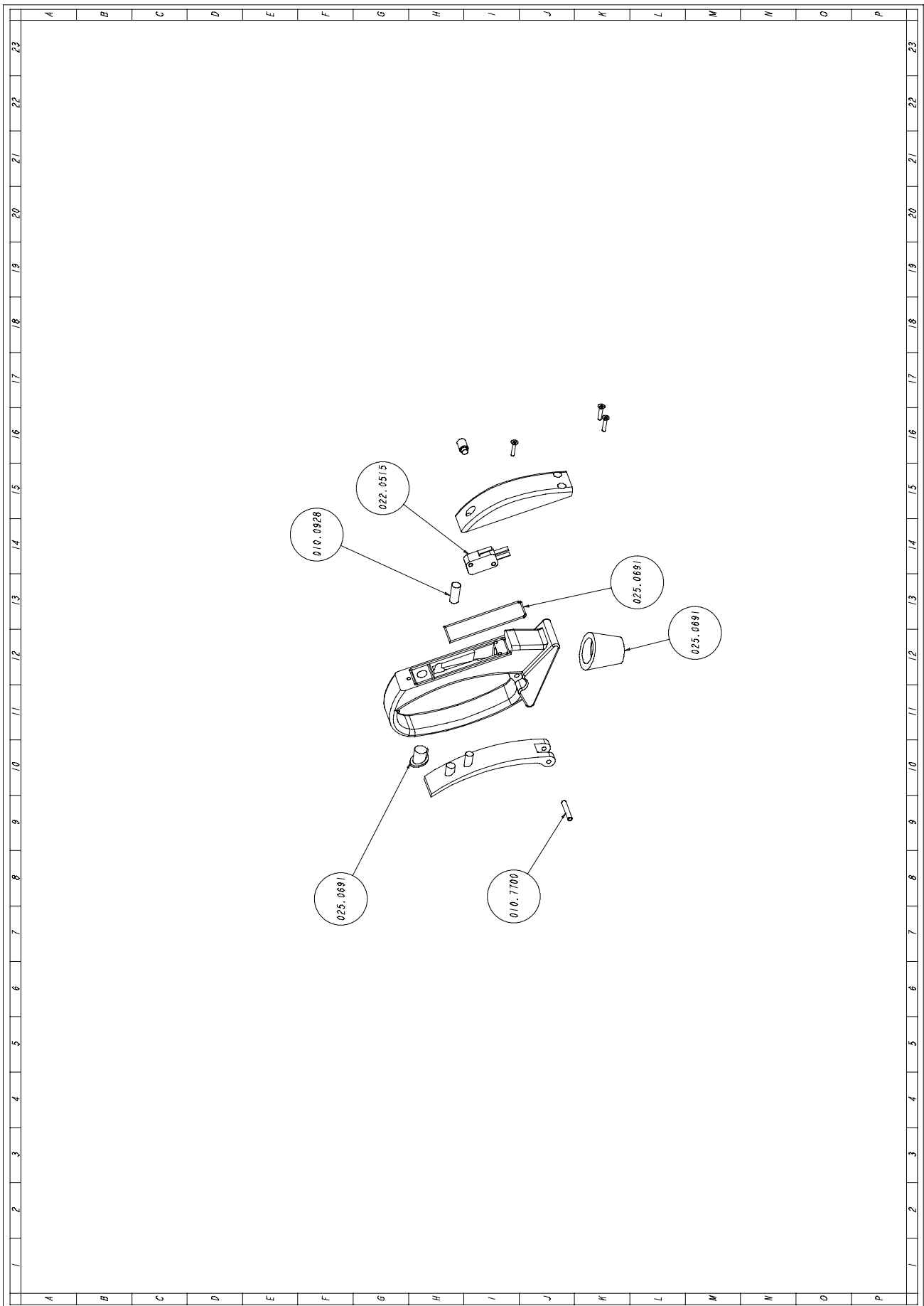

Art. Nr.	Benaming	M.	Hoeveelheid
010.0928	MEP HANDLE SPRING	NR	1,000
010.7409	8 X 10 CYLIND.POINT VCE GRUB SCREW	NR	1,000
010.7700	CYLINDRICAL PIN DIAM. 4 X 24	NR	1,000
010.7800	2,9 X 15 SELF- THREADING SCREW	NR	3,000
022.0515	MICROSWITCH V-21-1C6	NR	1,000
025.0691	GASKETS FOR MEP HANDLE	NR	1,000
034.1221	MEP HANDLE	NR	1,000

Zaagmotor

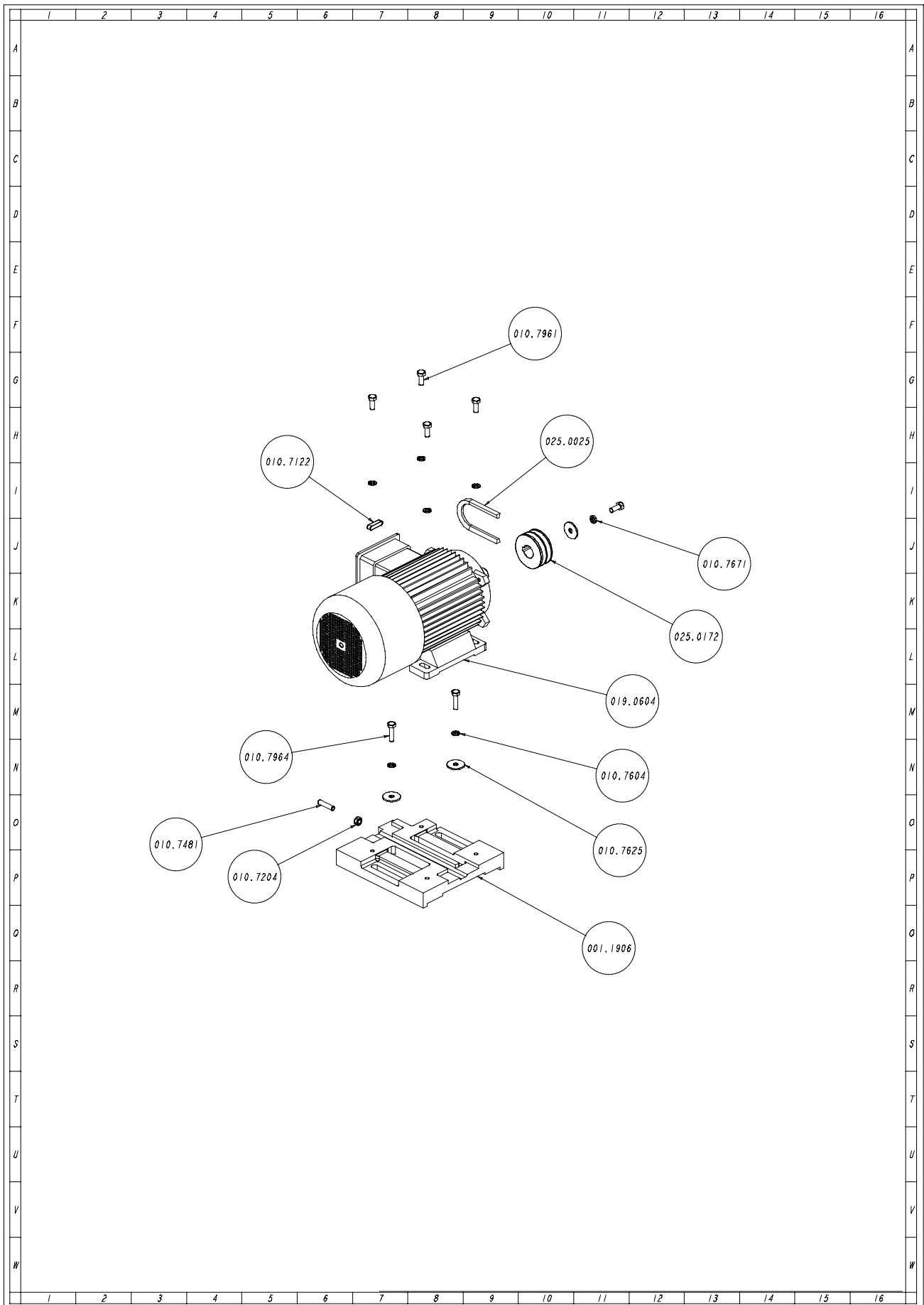

Art. Nr.	Benaming	M.	Hoeveelheid
001.1906	MOTOR PLANE CB 350 MOD.306	NR	1,000
010.7122	8 X 8 X 32 KEY	NR	1,000
010.7204	M8 SCREW NUT	NR	1,000
010.7481	8 X 35 FLAT POINT VCE GRUB SCREW	NR	1,000
010.7604	0 8 WASHER	NR	6,000
010.7625	0 8 X 32 WASHER	NR	3,000
010.7671	THICKNESS WASHER DIAM. 8 X 3	NR	1,000
010.7961	TE 8 X 20 SCREW	NR	5,000
010.7964	TE 8 X 30 SCREW	NR	2,000
019.0804	HP 2/3 2/4P B3 V380 C90L	NR	1,000
025.0025	BELT SPZ 900 S.TX	NR	2,000
025.0172	WHEEL 60X2 SPZ HOLE 24	NR	1,000
001.1902	ROTATING TABLE CB 350 MOD.302	NR	1,000
001.1903	ROTATING TABLE RING CB 350	NR	1,000
007.2366	ROTATING TABLE PLATE CB 350	NR	1,000
010.7205	M10 SCREW NUT	NR	2,000
010.7604	0 8 WASHER	NR	6,000
010.7767	ELASTIC PIN DIAM. 6 X 35	NR	2,000
010.7964	TE 8 X 30 SCREW	NR	6,000
010.7976	TE 10 X 30 SCREW	NR	2,000
010.7993	TSPEI 5 X 12 SCREW	NR	6,000

Klem

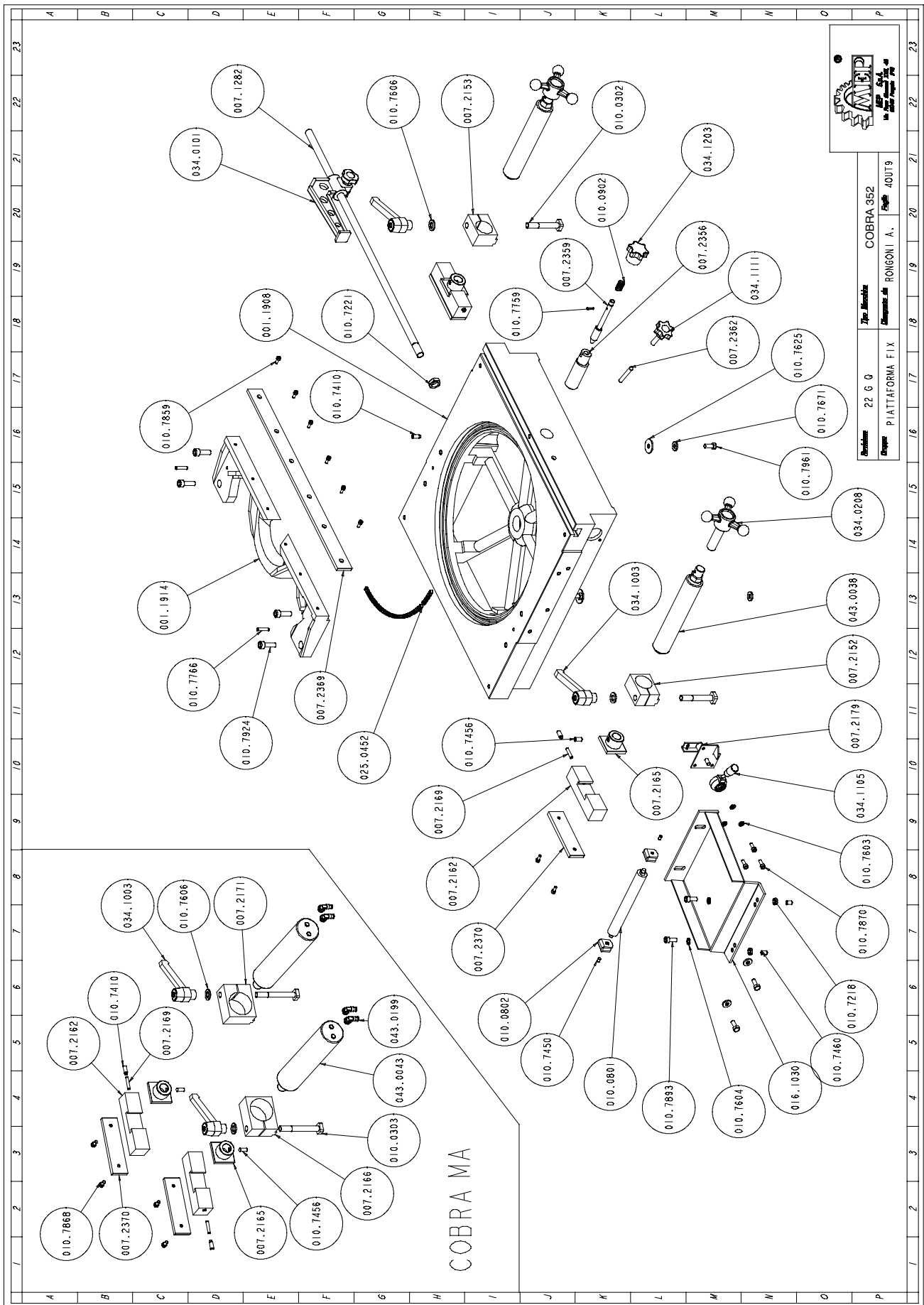

Revisione	22 G 0	Tip. Modifica	COBRA 352
Disegnata da	PIATTAFORMA FIX	Elaborata da	RONGONI A.
			Foglio 40/UT9

Art. Nr.	Benaming	Benaming	M.	Hoevee lheid
043.0199	4X1/8 TURNING ELBOW JOINT	ATTACCO A GOMITO GIREVOLE 4X1/8 CL 6521	PZ	4.000
043.0043	VICE CYLINDER 0 50	CILINDRO MORSE 0 50 C8 DE	PZ	2.000
007.2370	38X8 ADDITIONAL MOBILE JAW	GANASCIA MOBILE SUPPLEMENTARE 38X8	PZ	2.000
007.2162	VICE JAW CB 349/350	GANASCIA MORSA	PZ	2.000
034.1003	LEVER 12 MA	LEVA A SCATTO 12 MA	PZ	2.000
010.7868	TCEI 6 X 12 SCREW	VITE TCEI 6 X 12	PZ	4.000
010.7456	8 X 16 CONICAL POINT VCE GRUB SCREW	GRANO VCE PUNTA CONICA 8 X 16	PZ	2.000
010.7410	8 X 16 CYLIND.POINT VCE GRUB SCREW	GRANO VCE PUNTA CILINDRICA 8 X 16	PZ	2.000
007.2169	JAW LOCKING PIN	PERNO BLOCCAGGIO GANASCIA	PZ	2.000
010.7606	0 12 WASHER	RONDELLA 0 12	PZ	2.000
007.2171	VICE SLEEVE SUPPORT - RIGHT	SUPPORTO CANNOTTO MORSA DESTRA	PZ	1.000
007.2166	VICE SLEEVE SUPPORT - LEFT	SUPPORTO CANNOTTO MORSA	PZ	1.000
007.2165	VICE JAW SUPPORT	SUPPORTO GANASCIA MORSA	PZ	2.000
010.0303	SCREW 22X22 M12X95	VITE TESTA QUADRA 22X22 M 12X95	PZ	2.000

Art. Nr.	Benaming	Benaming	M.	Hoevee lheid
007.2179	UNLOCKING HEAD SYSTEM	GRUPPO SBLOCCAGGIO TESTA	PZ	1.000
007.1282	MEASURE ROD CUT	ASTA TAGLI A MISURA	PZ	1.000
001.1908	BASE	BASAMENTO	PZ	1.000
034.0101	LARGE CUT TO MEASURE STOP	BATTUTA TAGLI A MISURA GRANDE	PZ	1.000
016.1030	BAR SUPPORT ARM	BRACCETTO APPOGGIA BARRA	PZ	1.000
043.0038	CYLINDER 20 M	CILINDRO 20 M	PZ	2.000
010.7221	M16 LOW SCREW NUT	DADO M16 BASSO	PZ	1.000
010.7218	M8 LOW SCREW NUT	DADO M8 BASSO	PZ	2.000
007.2356	ECCENTRIC FIXED POINT	ECCENTRICO PUNTO FISSO	PZ	1.000
007.2369	38X8 ADDITIONAL FIXED JAW	GANASCIA FISSA SUPPLEMENTARE 38X8	PZ	1.000
007.2370	38X8 ADDITIONAL MOBILE JAW	GANASCIA MOBILE SUPPLEMENTARE 38X8	PZ	2.000
007.2162	VICE JAW	GANASCIA MORSA	PZ	2.000
007.2179	UNLOCKING HEAD SYSTEM	GRUPPO SBLOCCAGGIO TESTA	PZ	1.000
034.1003	LEVER 12 MA	LEVA A SCATTO 12 MA	PZ	2.000
010.7924	TCEI 10 X 30 SCREW	VITE TCEI 10 X 30	PZ	4.000
010.7859	TCEI 5 X 12 SCREW	VITE TCEI 5 X 12	PZ	10.000
010.7870	TCEI 6 X 16 SCREW	VITE TCEI 6 X 16	PZ	3.000
010.7450	6 X 6 CYLINDRICAL POINT VCE GRUB	GRANO VCE PUNTA CONICA 6 X 6	PZ	2.000
010.7460	8 X 12 CONICAL POINT VCE GRUB SCREW	GRANO VCE PUNTA CONICA 8 X 12	PZ	2.000
010.7456	8 X 16 CONICAL POINT VCE GRUB SCREW	GRANO VCE PUNTA CONICA 8 X 16	PZ	2.000
010.7410	8 X 16 CYLIND.POINT VCE GRUB SCREW	GRANO VCE PUNTA CILINDRICA 8 X 16	PZ	3.000
010.7893	TCEI 8 X 20 SCREW	VITE TCEI 8 X 20	PZ	2.000
010.7961	TE 8 X 20 SCREW	VITE TE 8 X 20	PZ	4.000
010.0902	HEAD FIXED POINT SPRING	MOLLA PUNTO FISSO TESTA	PZ	1.000
007.2362	TURN TABLE LOCKING PIN	PERNO BLOCCAGGIO PIANO GIREVOLE	PZ	1.000
007.2169	JAW LOCKING PIN	PERNO BLOCCAGGIO GANASCIA	PZ	2.000
007.2359	FIXED POINT PIN	PERNO PUNTO FISSO	PZ	1.000
010.7606	0 12 WASHER	RONDELLA 0 12	PZ	2.000
010.7603	0 6 WASHER	RONDELLA 0 6	PZ	3.000
010.7604	0 8 WASHER	RONDELLA 0 8	PZ	2.000
010.7671	THICKNESS WASHER DIAM. 8 X 3	RONDELLA SPESSORE DIAM. 8 X 3	PZ	4.000
010.7625	0 8 X 32 WASHER	RONDELLA 0 8 X 32	PZ	2.000
025.0452	ROLLERS 6X6 AISI 420	RULLI 6X6 AISI 420	PZ	60.000
010.0801	ROLLER 304011 0 24	RULLO TIPO 304011 0 24	PZ	1.000
010.7759	ELASTIC PIN DIAM. 3 X 16	SPINA ELASTICA DIAM. 3 X 16	PZ	1.000
010.7766	ELASTIC PIN DIAM. 6 X 30	SPINA ELASTICA DIAM. 6 X 30	PZ	2.000

Art. Nr.	Benaming	Benaming	M.	Hoeveelheid
001.1914	VICE BACK STOP CB 350	SQUADRO MORSA	PZ	1.000
007.2165	VICE JAW SUPPORT CB 349/350	SUPPORTO GANASCIA MORSA	PZ	2.000
007.2153	VICE SLEEVE SUPPORT DESTRO	SUPPORTO CANNOTTO MORSA DESTRO	PZ	1.000
007.2152	VICE SLEEVE SUPPORT	SUPPORTO CANNOTTO MORSA	PZ	1.000
010.0802	ROLLER SUPPORT	SUPPORTO PER RULLO CB-TI-FC	PZ	2.000
010.0302	SCREW 22X22 M12X80	VITE TESTA QUADRA 22X22 M 12X80	PZ	2.000
034.1203	MEP MADE HANDWHEEL M10	IMPUGNATURA NS. DISEGNO M10	PZ	1.000
034.0208	M20X70 SMALL VICE HANDWHEEL	VOLANTINO MORSA PICCOLO M20X70	PZ	2.000
034.1105	HANDWHEEL	VOLANTINO DI MANOVRA	PZ	1.000
034.1111	O 30 M10 X 40 HANDWHEEL	VOLANTINO O 30 M10 X 40	PZ	1.000

Ondersteuning kippunt hoofd

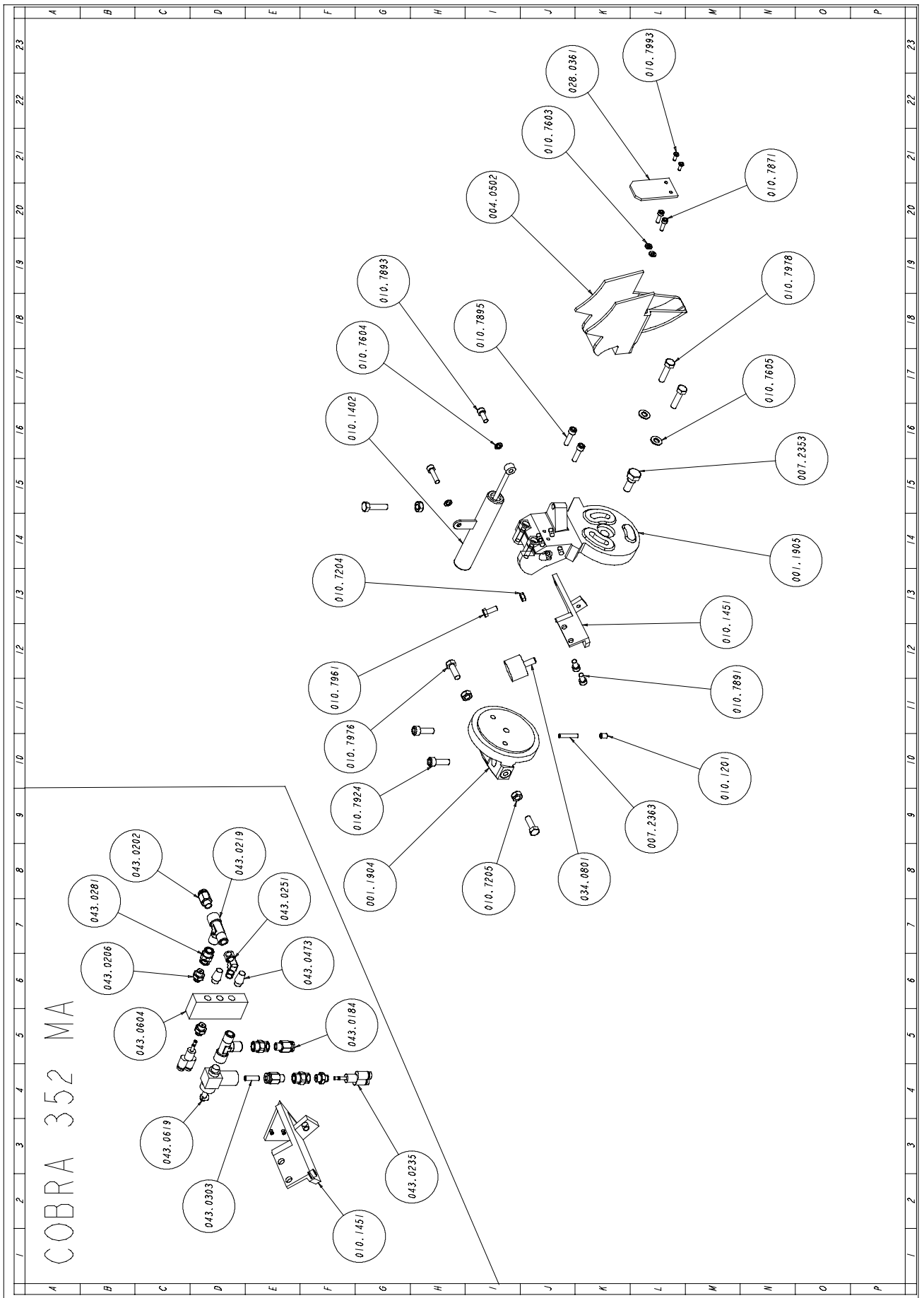

Art. Nr.	Benaming	M.	Hoeveelheid
001.1904	SUPPORT CB 350 MOD.304	NR	1,000
001.1905	SUPPORT CB 350 MOD.305	NR	1,000
004.0502	FIXED PROTECTION CB 350 N.S.	NR	1,000
007.2353	HEX. SCREW CB 350	NR	1,000
007.2363	PIN CB 350	NR	1,000
010.1402	HEAD RETURN SPRING CB 350	NR	1,000
010.1451	PUMP BRACKET CB 350	NR	1,000
010.7204	M8 SCREW NUT	NR	1,000
010.7205	M10 SCREW NUT	NR	3,000
010.7402	6 X 12 CYLIND.POINT VGE GRUB SCREW	NR	1,000
010.7603	0 6 WASHER	NR	2,000
010.7604	0 8 WASHER	NR	2,000
010.7605	0 10 WASHER	NR	2,000
010.7871	TCEI 6 X 20 SCREW	NR	2,000
010.7891	TCEI 8 X 16 SCREW	NR	2,000
010.7893	TCEI 8 X 20 SCREW	NR	1,000
010.7895	TCEI 8 X 30 SCREW	NR	3,000
010.7924	TCEI 10 X 30 SCREW	NR	2,000
010.7961	TE 8 X 20 SCREW	NR	1,000
010.7976	TE 10 X 30 SCREW	NR	2,000
010.7978	TE 10 X 40 SCREW	NR	3,000
010.7993	TSPEI 5 X 12 SCREW	NR	2,000
028.0361	BLADE COVER RUBBER JOINT CB 350	NR	1,000
034.0801	ELASTIC STOP P 40/30 CB-RA350 SH 260-270	NR	1,000
043.0206	HEXAGONAL COUPLING 4X1/8	NR	3,000
043.0184	HEXAGONAL COUPLING 6X1/8	NR	2,000
043.0202	HEXAGONAL COUPLING 8X1/8	NR	1,000
043.0235	Y BRANCHING 4 MM PIPE	NR	2,000
043.0251	M.F. ELBOW 1/8	NR	1,000
043.0281	1/8 M 8/8 SLEEVE	NR	3,000
043.0218	MFF T JOINT	NR	2,000
043.0473	1/8 SILENCER	NR	2,000
016.0354	VALVE FIXING BRACKET	NR	1,000
043.0303	RILSAN HOSE 6X4	NR	1,000
043.0604	358 990 VALVE	NR	1,000
043.0619	PWBA 1468 BLOCK INTERCEPTOR	NR	1,000

Draaitafel

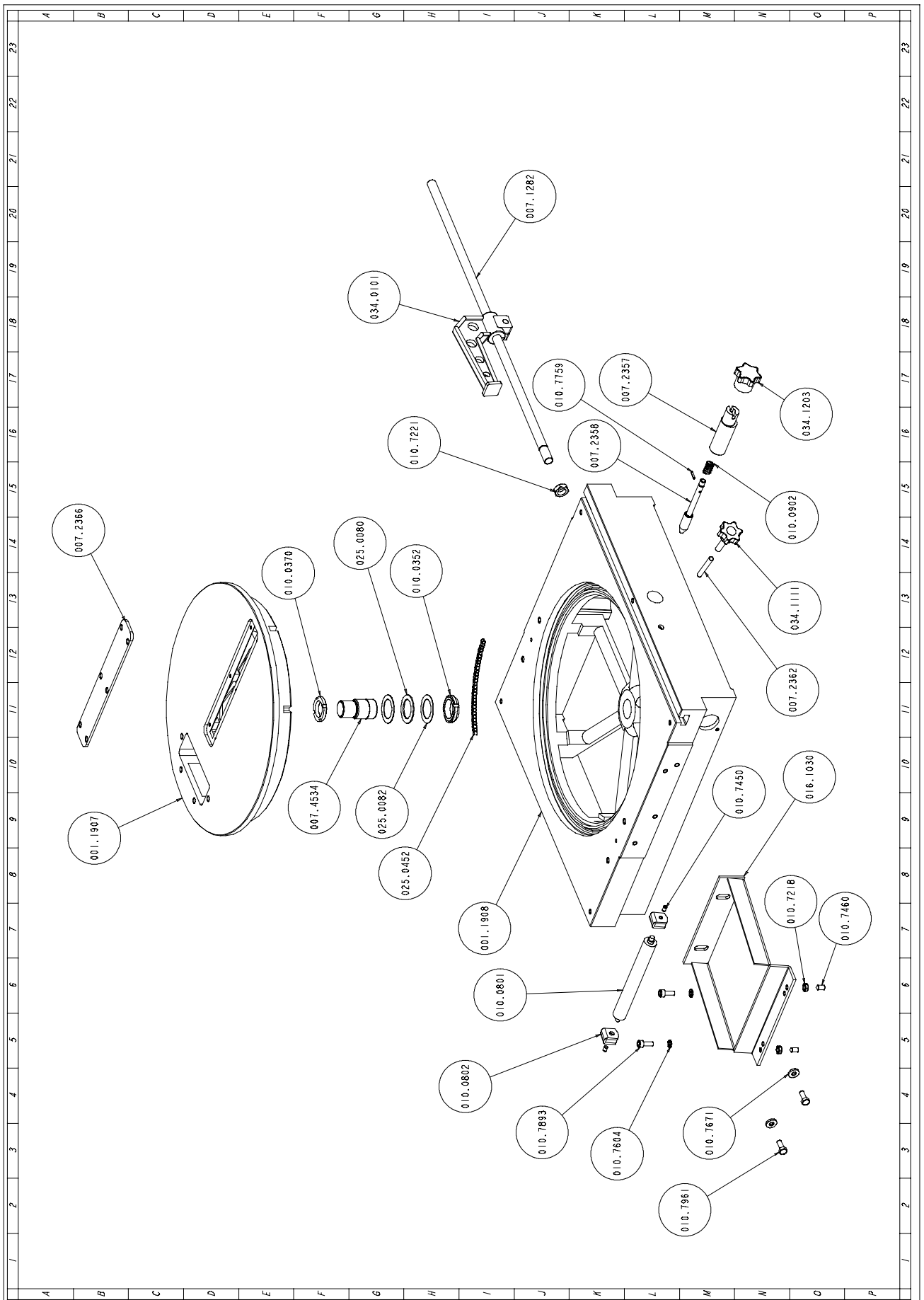

Art. Nr.	Benaming	M.	Hoeveelheid
001.1907	PIANO GIREVOLE CB 350 N.T.	NR	1,000
001.1908	BASAMENTO CB 350 N.T. MOD	NR	1,000
007.1282	ASTA TAGLI A MISURA	NR	1,000
007.2356	ECCENTRICO PUNTO FISSO	NR	1,000
007.2359	PERNO PUNTO FISSO CB 350 N.T.	NR	1,000
007.2362	PERNO BLOCCAGGIO PIANO GIREVOL	NR	1,000
007.2366	PIASTRA PIANO GIREVOLE CB 350	NR	1,000
007.4534	PERNO DI CENTRO	NR	1,000
010.0352	GHIERA AUTOBLOCCANTE 35X1,5	NR	1,000
010.0370	GHIERA 5S 30X1,5	NR	1,000
010.0801	RULLO TIPO	NR	1,000
010.0802	SUPPORTO PER RULLO	NR	2,000
010.0902	MOLLE PUNTO FISSO TESTA	NR	1,000
010.7218	DADO M8 BASSO	NR	2,000
010.7221	DADO M16 BASSO	NR	1,000
010.7450	GRANO VCE P.CIL. 6 X 6	NR	2,000
010.7460	GRANO VCE P.CON. 8 X 12	NR	2,000
010.7604	RONDELLA DIAM. 8	NR	2,000
010.7671	RONDELLA SPESSORE DIAM. 8 X 3	NR	2,000
010.7759	SPINA ELASTICA DIAM. 3 X 16	NR	1,000
010.7893	VITE TCEI 8 X 20	NR	2,000
010.7961	VITE TE 8 X 20	NR	2,000
016.1030	BRACCETTO APPOGGIA BARRA	NR	1,000
025.0080	GABBIA ASSIALE A RULLINI AXK 3	NR	1,000
025.0082	RALLA AS 3552	NR	2,000
025.0452	RULLI 6X6 AISI 420	NR	30,000
034.0101	BATTUTA TAGLI A MISURA GRANDE	NR	1,000
034.1111	VOLANTINO DIAM.30 M10 X 40	NR	1,000
034.1203	IMPUGNATURA NS. DISEGNO M10	NR	1,000

Enheid ter afdekking zaagblad

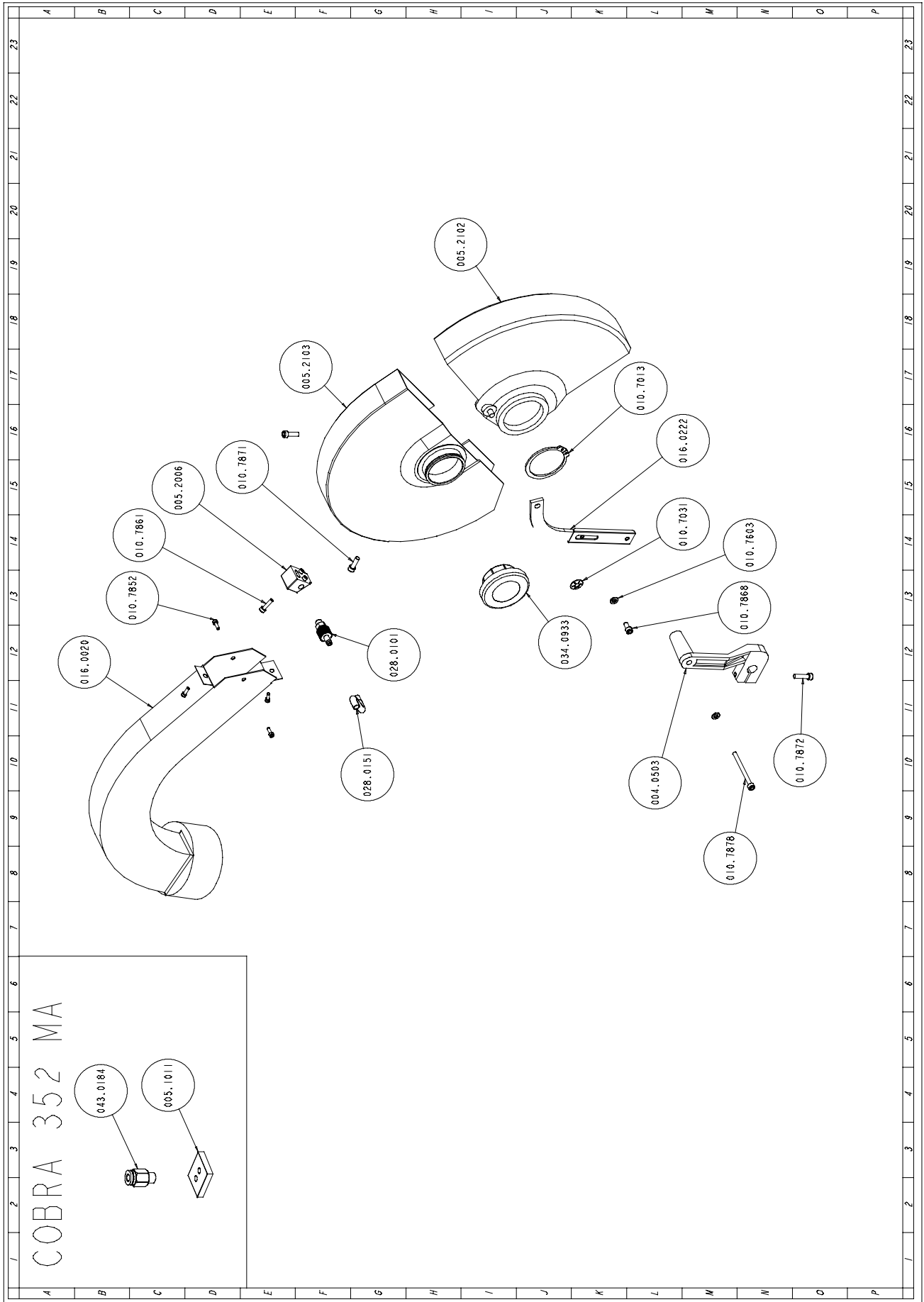

Art. Nr.	Benaming	M.	Hoeveelheid
004.0503	PROTECTION ROD SUPPORT CB 350	NR	1,000
005.2006	TAP SPRAYER CB 350	NR	1,000
005.2102	BLADE PROTECTION 0 350	NR	1,000
005.2103	BLADE COVER CB 350	NR	1,000
010.7013	0 62 SEEGER RING	NR	1,000
010.7031	SK 0 8 SEEGER RING	NR	1,000
010.7603	0 6 WASHER	NR	2,000
010.7852	TCEI 4 X 12 SCREW	NR	4,000
010.7861	TCEI 5 X 20 SCREW	NR	1,000
010.7868	TCEI 6 X 12 SCREW	NR	1,000
010.7871	TCEI 6 X 20 SCREW	NR	2,000
010.7872	TCEI 6 X 25 SCREW	NR	1,000
010.7878	TCEI 6 X 70 SCREW	NR	1,000
016.0020	SWARF CONVEYOR CB 350	NR	1,000
016.0222	GUARD BRACKET CB 350 N.S.	NR	1,000
028.0101	TAP REGULATOR 8 X 1/4	NR	1,000
028.0151	PLASTIC HOSE 07-11	KG	0,120
034.0933	BLADE COVER TAP	NR	1,000

Onderstel

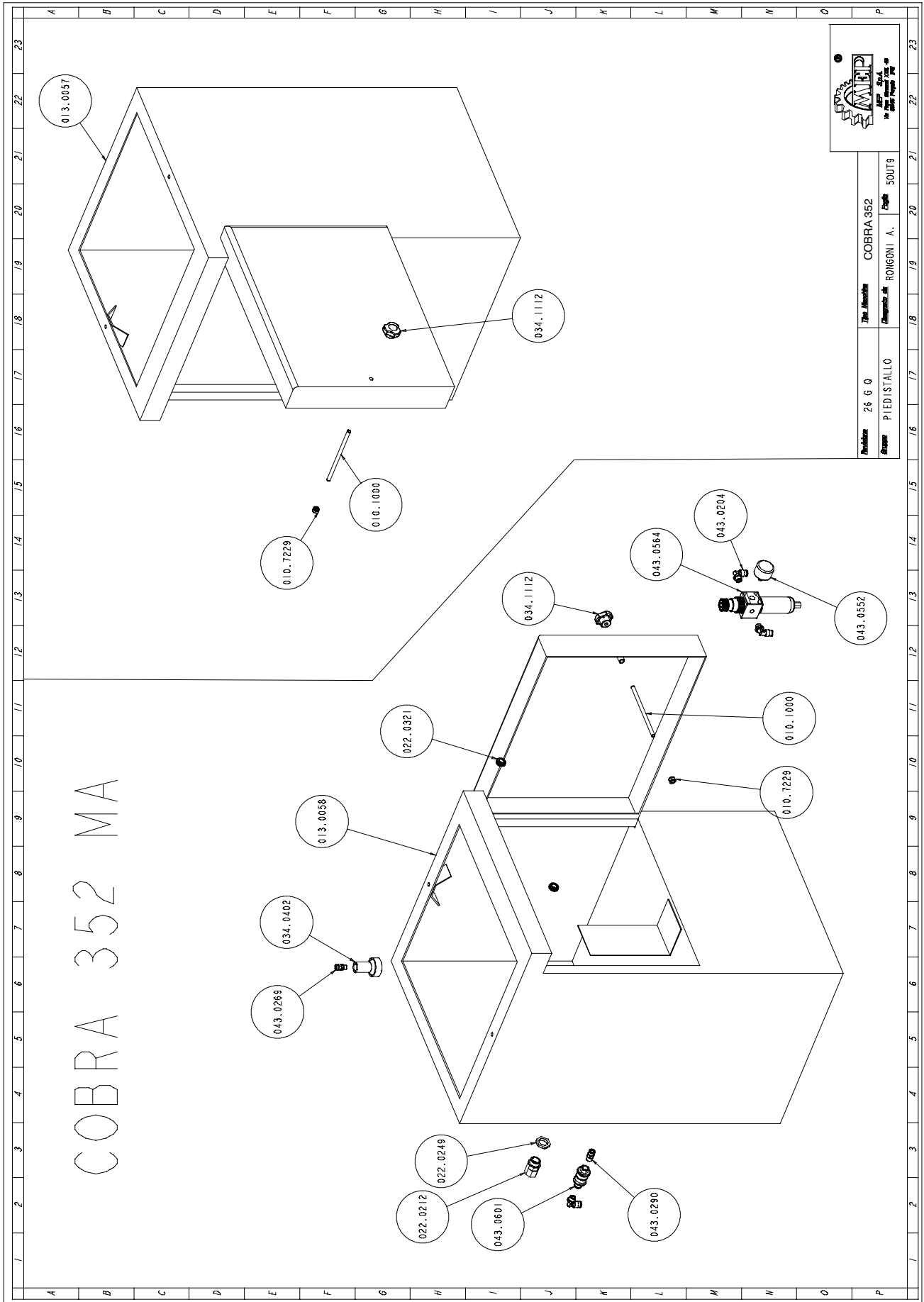

Art. Nr.	Benaming	M.	Hoeveelheid
010.1000	8 MA THREADED BAR	MT	1,000
010.7229	M8 SELF-LOCKING SCREW NUT	NR	1,000
013.0057	STEEL BASE CB 350	NR	1,000
013.0058	STEEL BASE CB 350 MA	NR	1,000
016.0354	VALVE FIXING BRACKET CB 350 MA	NR	1,000
022.0212	RAPID JOINT SEM PG 16	NR	1,000
022.0249	POLYAMIDE HUMMEL NUT 1.262.1600.11	NR	1,000
022.0321	FAIRLEADS 12 INC.M M.2	NR	2,000
034.0402	FOOT VALVE	NR	1,000
034.1112	O 40 M8 HANDWHEEL X STEEL BASE SH	NR	1,000
043.0204	8X1/4 - CL 6521 ELBOW COUPLING	NR	3,000
043.0269	CL 1500 6/4 1/8 STRAIGHT JOINT	NR	1,000
043.0290	1/4 QUICK COUPLING	NR	1,000
043.0552	MANOMETER 0 40	NR	1,000
043.0564	FR 1/4 20-08	NR	1,000
043.0601	VMS 114-1/4 08 VALVE	NR	1,000

Bedienveld Eenheid

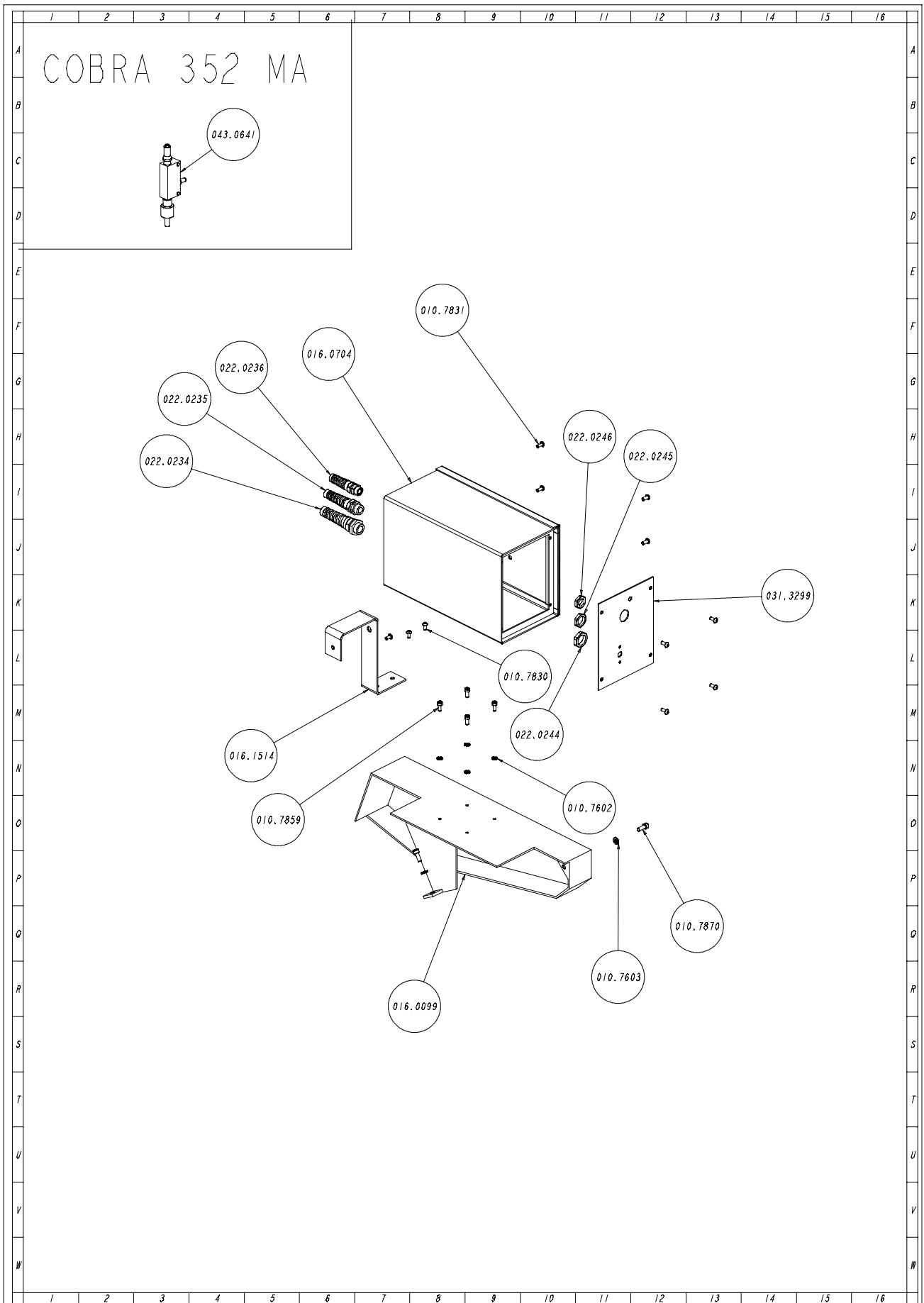

Art. Nr.	Benaming	M.	Hoeveelheid
010.7602	0 5 WASHER	NR	4,000
010.7603	0 6 WASHER	NR	2,000
010.7830	5 X 10 BUTON SCREW	NR	3,000
010.7831	5 X 12 BUTON SCREW	NR	8,000
010.7859	TCEI 5 X 12 SCREW	NR	4,000
010.7870	TCEI 6 X 16 SCREW	NR	2,000
016.0099	BELT COVER CB 350	NR	1,000
016.0704	LVD CONTROL PANEL CB 350	NR	1,000
016.1514	SWARF CONVEYOR FIX BRACKET CB 350	NR	1,000
022.0234	CORD PRESSER	NR	1,000
022.0235	CORD PRESSER	NR	1,000
022.0236	CORD PRESSER	NR	1,000
022.0244	LOCK NUT 3217B GREY PG 13,5	NR	1,000
022.0245	LOCK NUT 3213B GREY PG 11	NR	1,000
022.0246	LOCK NUT 3210B GREY PG 9	NR	1,000
031.3299	SWITCH PLATE CB 350	NR	1,000
043.0641	T.7240201 COOLANT SPRAYER	NR	1,000